

# Contents

<b>Section 1</b>	<b>Caution Statements .....</b>	<b>3</b>
<b>Section 2</b>	<b>Installation.....</b>	<b>4</b>
2.1	Physical Installation .....	4
2.2	Control Terminals .....	4
2.3	Control Wiring.....	4
2.4	Power Terminations.....	5
<b>Section 3</b>	<b>Power Circuits.....</b>	<b>6</b>
3.1	Motor Connection .....	6
3.2	Bypass Contactor.....	9
3.3	Main Contactor.....	9
3.4	Circuit Breaker.....	9
3.5	Power Factor Correction .....	9
3.6	Fuses.....	10
3.7	Earth Terminal .....	10
3.8	Schematic Diagrams .....	11
<b>Section 4</b>	<b>Keypad and Feedback.....</b>	<b>13</b>
4.1	The Keypad .....	13
4.2	Displays.....	14
<b>Section 5</b>	<b>Maintenance Tools.....</b>	<b>18</b>
5.1	Commissioning Menu.....	18
5.2	Logs Menu.....	21
<b>Section 6</b>	<b>Operation.....</b>	<b>23</b>
6.1	Start, Stop and Reset Commands.....	23
6.2	Soft Start Methods.....	23
6.3	Stop Methods .....	26
6.4	Jog Operation.....	28
<b>Section 7</b>	<b>Programming Menu .....</b>	<b>29</b>
7.1	Programming Menu .....	29
7.2	Adjustment Lock.....	30
7.3	Access Code.....	30
7.4	Quick Setup .....	30
7.5	Standard Menu .....	32
7.6	Extended Menu.....	33
7.7	Load/Save Settings.....	36
7.8	Parameter Descriptions.....	37
<b>Section 8</b>	<b>Troubleshooting.....</b>	<b>56</b>
8.1	Trip Messages.....	56
8.2	Protection Responses.....	57
8.3	General Faults .....	58
<b>Section 9</b>	<b>Appendix.....</b>	<b>60</b>
9.1	Specifications .....	60
9.2	Accessories.....	64
9.3	Parameter Values .....	65

Section 10    Authorised Representatives .....69

## Section I Caution Statements



This symbol is used throughout this manual to draw attention to topics of special importance to the installation and operation of EMX3 soft starters.

Caution Statements cannot cover every potential cause of equipment damage but can highlight common causes of damage. It is the installer's responsibility to follow all instructions in this manual, to follow good electrical practice and to seek advice before operating this equipment in a manner other than as described in this manual.

The examples and diagrams in this manual are included solely for illustrative purposes. The information contained in this manual is subject to change at any time and without prior notice. In no event will responsibility or liability be accepted for direct, indirect or consequential damages resulting from the use or application of this equipment.



### WARNING - ELECTRICAL SHOCK HAZARD

EMX3 soft starters contain dangerous voltages when connected to mains voltage. Only a competent electrician should carry out the electrical installation. Improper installation of the motor or the soft starter may cause equipment failure, serious injury or death. Follow this manual and local electrical safety codes.



### SHORT CIRCUIT

EMX3 soft starters are not short circuit proof. After severe overload or short circuit, the operation of the soft starter should be fully tested.



### GROUNDING AND BRANCH CIRCUIT PROTECTION

It is the responsibility of the user or person installing the soft starter to provide proper grounding and branch circuit protection according to local electrical safety codes.

**Section 2 Installation**

**2.1 Physical Installation**

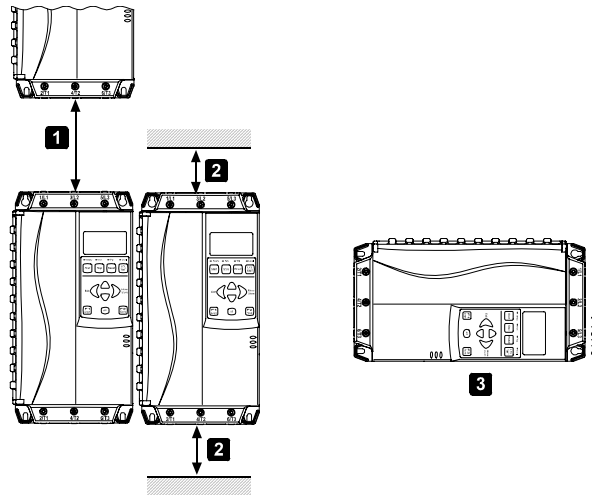

<b>1</b>	EMX3-0023B ~ EMX3-0255C: Allow 100 mm (3.94 inches) between soft starters. EMX3-0360C ~ EMX3-1600C: Allow 200 mm (7.88 inches) between soft starters.
<b>2</b>	EMX3-0023B ~ EMX3-0220B: Allow 50 mm (1.97 inches) between the soft starter and solid surfaces. EMX3-0255C: Allow 100 mm (3.94 inches) between the soft starter and solid surfaces. EMX3-0360C ~ EMX3-1600C: Allow 200 mm (7.88 inches) between the soft starter and solid surfaces.
<b>3</b>	The soft starter may be mounted on its side. Derate the soft starter's rated current by 15%.

Soft starters may be mounted side by side with no clearance.

**2.2 Control Terminals**

Control terminations use 2.5mm<sup>2</sup> plug-in terminal blocks. Unplug each block, complete the wiring, then reinsert the block.

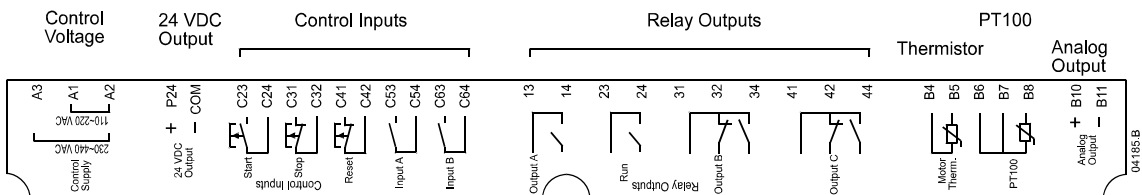

**2.3 Control Wiring**

The EMX3 has three fixed inputs for remote control. These inputs should be controlled by contacts rated for low voltage, low current operation (gold flash or similar).

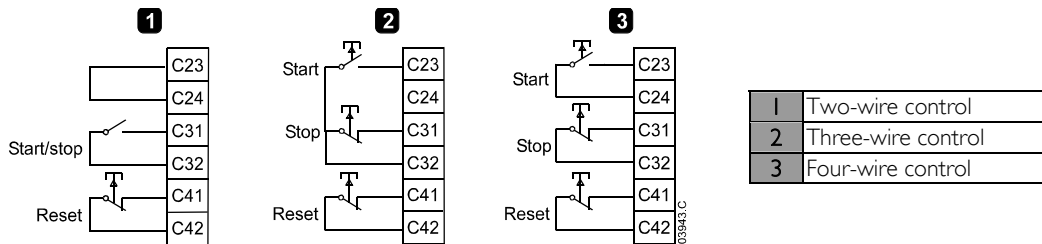

The reset input can be normally open or normally closed. User parameter 6M to select the configuration.



**CAUTION**

Do not apply voltage to the control input terminals. These are active 24 VDC inputs and must be controlled with potential free contacts.

Cables to the control inputs must be segregated from mains voltage and motor cabling.

**2.4 Power Terminations**

Use 75 °C Cu stranded or solid conductors only.

Power (L1/T1, L2/T2, L3/T3)		
<p>14 (0.55) mm (inch)</p>		<p>Cable sizes mm<sup>2</sup>    AWG 10-50    8-1/0</p>
	<p>Torx T20 x 150</p>	<p>Torque Nm        Ft-lb 3-4        2.2-2.9</p>
	<p>Flat 7mm x 150</p>	

EMX3-0023B ~ EMX3 0105B

Use 75 °C Cu - Al stranded or solid conductors only.

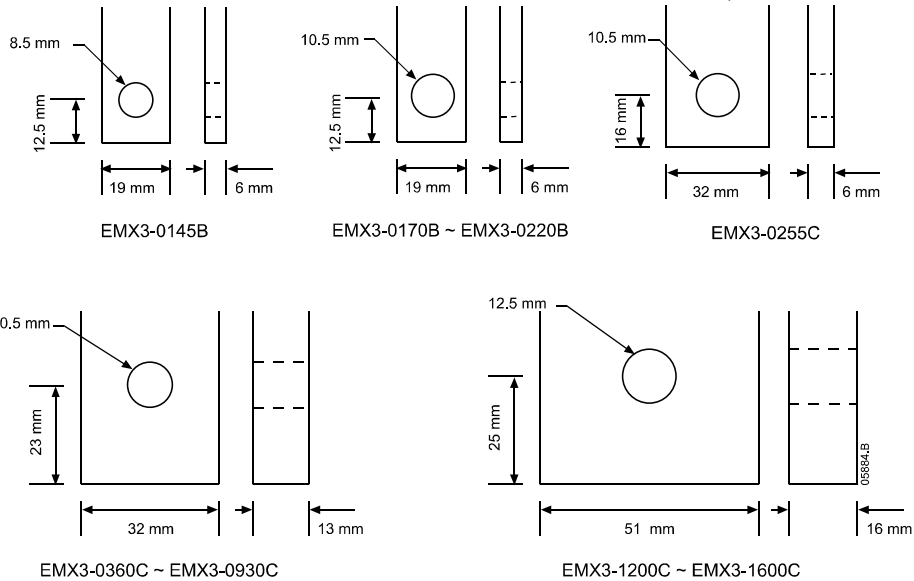

The bus bars on models EMX3-0360C ~ EMX3-1600C can be adjusted for top or bottom input and output as required. For step-by-step instructions on adjusting the bus bars, contact your supplier.

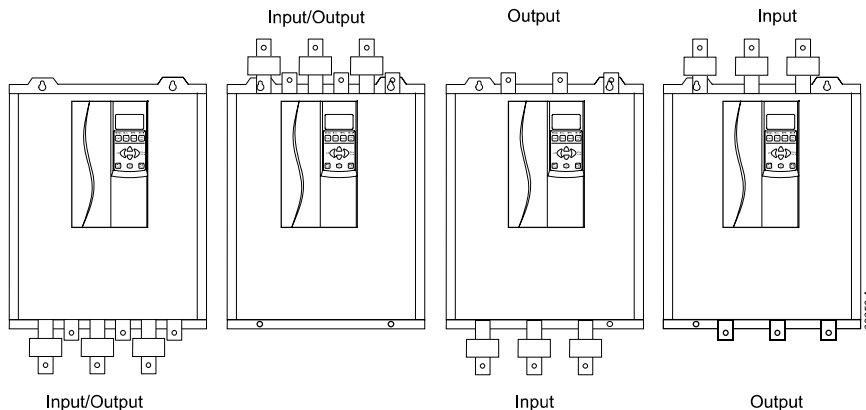

**Section 3 Power Circuits**

**3.1 Motor Connection**

EMX3 soft starters can be connected to the motor in-line or inside delta (also called three-wire and six-wire connection). Motor Full Load Current (FLC) need only be programmed as per the motor nameplate FLC. The EMX3 will automatically detect the motor connection and do the necessary calculations internally.



**NOTE**

For personnel safety, the power terminals on models up to EMX3-0105B are protected by snap-off tabs. When using large cables, it may be necessary to break off these tabs.

Models which are internally bypassed do not require an external bypass contactor.

**In-line installation, internally bypassed**

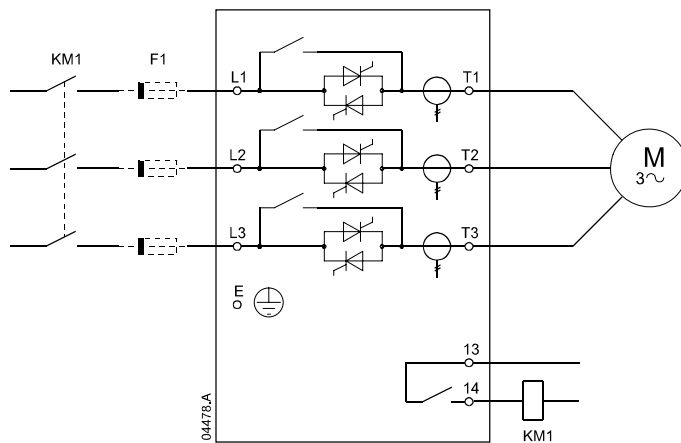

KM1	Main contactor
F1	Semiconductor Fuses (optional)

**In-line installation, externally bypassed**

Non-bypassed models have dedicated bypass terminals, which allow the EMX3 to continue providing protection and monitoring functions even when bypassed.

The bypass contactor must be connected to the bypass terminals (L1B, L2B, L3B) and controlled by the soft starter's run output (terminals 23, 24).

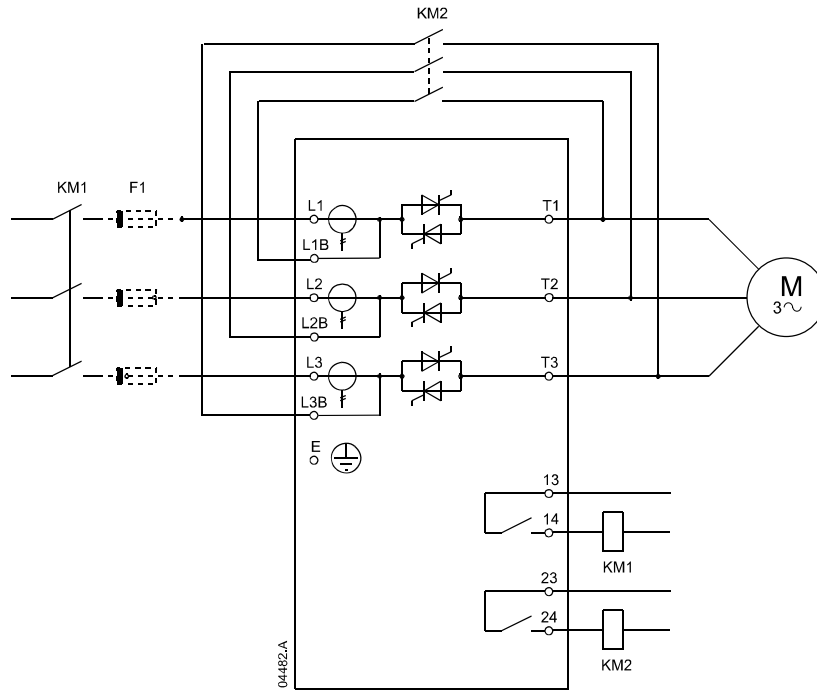

KM1	Main contactor
KM2	Bypass contactor
F1	Semiconductor Fuses (optional)

**In-line installation, non-bypassed**

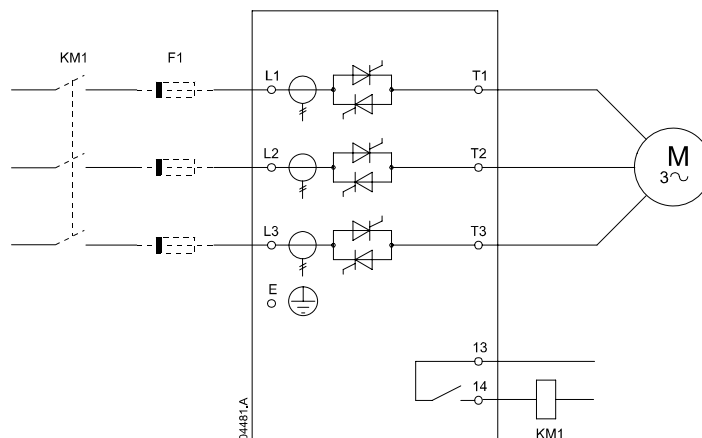

KM1	Main contactor
F1	Semiconductor Fuses (optional)



## CAUTION

When connecting the EMX3 in inside delta configuration, always install a main contactor or shunt trip circuit breaker.

### Inside delta installation, internally bypassed

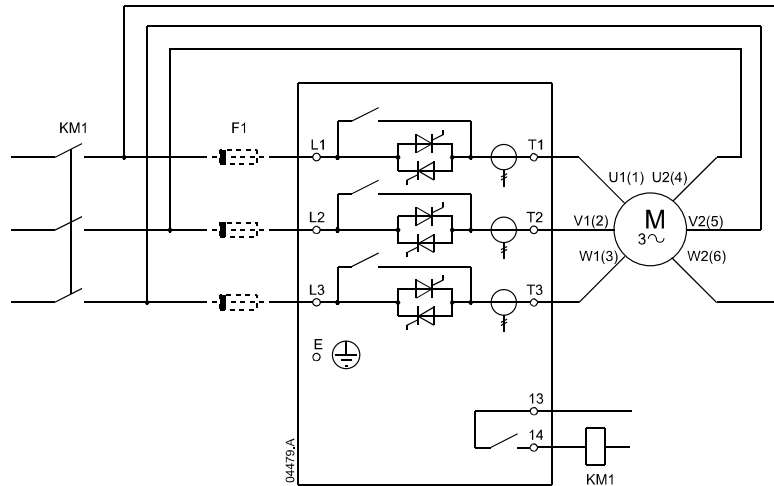

KM1	Main contactor
F1	Semi-conductor Fuses (optional)

### Inside delta installation, externally bypassed

Non-bypassed models have dedicated bypass terminals, which allow the EMX3 to continue providing protection and monitoring functions even when bypassed.

The bypass contactor must be connected to the bypass terminals (L1B, L2B, L3B) and controlled by the soft starter's run output (terminals 23, 24).

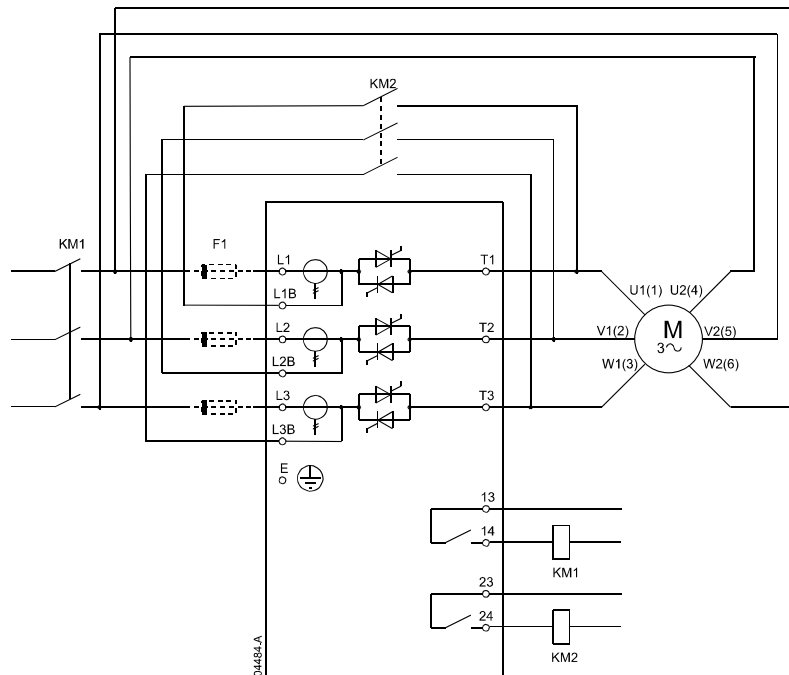

KM1	Main contactor
KM2	Bypass contactor
F1	Semicondual Fuses (optional)

## Inside delta installation, non-bypassed

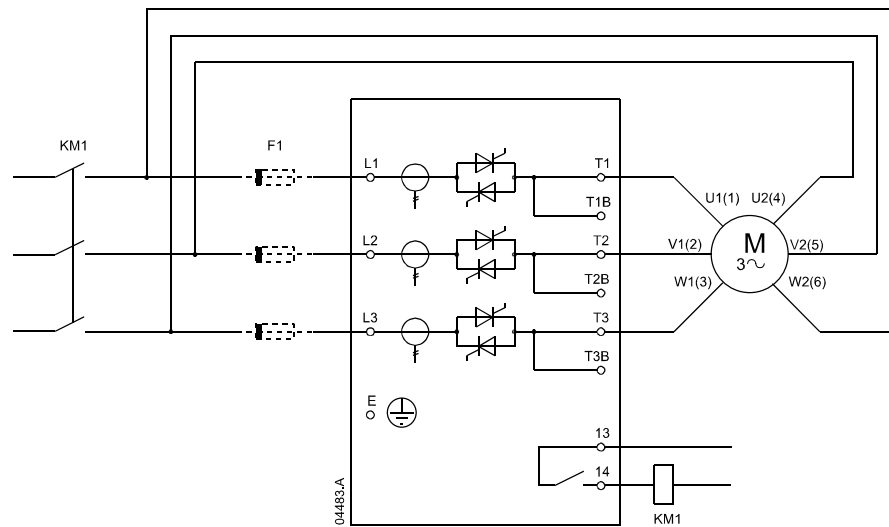

KM1	Main contactor
F1	Semi-conductor Fuses (optional)

### 3.2 Bypass Contactor

EMX3 soft starters with model numbers EMX3-0023B ~ EMX3-0220B are internally bypassed and do not require an external bypass contactor.

EMX3 soft starters with model numbers EMX3-0255C ~ EMX3-1600C are not internally bypassed and may be installed with an external bypass contactor. Select a contactor with an AC1 rating greater than or equal to the full load current rating of the connected motor.

### 3.3 Main Contactor

A main contactor must be installed if the EMX3 is connected to the motor in inside delta format and is optional for in-line connection. Select a contactor with an AC3 rating greater than or equal to the full load current rating of the connected motor.

### 3.4 Circuit Breaker

A shunt trip circuit breaker may be used instead of a main contactor to isolate the motor circuit in the event of a soft starter trip. The shunt trip mechanism must be powered from the supply side of the circuit breaker or from a separate control supply.

### 3.5 Power Factor Correction

If power factor correction is used, a dedicated contactor should be used to switch in the capacitors. Power factor correction capacitors must be connected to the input side of the soft starter. Connecting power factor correction capacitors to the output side will damage the soft starter.

**3.6 Fuses**

Semiconductor fuses can be used with the EMX3 for Type 2 coordination and to reduce the potential for damage to SCRs from transient overload currents. For fuse information on 690 VAC units contact your local supplier.

Model	SCR I2t (A2s)	Bussmann Fuse Square Body (170M)	Bussmann Fuse British Style (BS88)	Ferraz Fuse (HSJ)	Ferraz Fuse European Style (PSC 690)	Ferraz Fuse N. American Style (PSC 690)
EMX3-0023B	1150	170M1314	63FE	HSJ40 **	6.9URD30D11A0050	A070URD30XXX0063
EMX3-0043B	8000	170M1318	120FEE	HSJ60	6.9URD30D11A0125	A070URD30XXX0125
EMX3-0050B	10500	170M1318	200FEE	HSJ80 **	6.9URD30D11A0125	A070URD30XXX0125
EMX3-0053B	15000	170M1318	200FEE	HSJ90 **	6.9URD30D11A0125	A070URD30XXX0125
EMX3-0076B	15000	170M1319	200FEE	HSJ110 **	6.9URD30D11A0200	A070URD30XXX0200
EMX3-0097B	51200	170M1321	280FM	HSJ150	6.9URD30D11A0200	A070URD30XXX0200
EMX3-0100B	80000	170M1321	280FM	HSJ175	6.9URD30D11A0200	A070URD30XXX0200
EMX3-0105B	125000	170M1321	280FM	HSJ225	6.9URD30D11A0315	A070URD30XXX0315
EMX3-0145B	125000	170M2621	280FM	HSJ250	6.9URD30D11A0315	A070URD30XXX0315
EMX3-0170B	320000	170M2621	450FMM	HSJ300	6.9URD30D11A0315	A070URD30XXX0315
EMX3-0200B	320000	170M2621	450FMM	HSJ350	6.9URD31D11A0450	A070URD30XXX0450
EMX3-0220B	320000	170M2621	450FMM	HSJ350	6.9URD31D11A0450	A070URD30XXX0450
EMX3-0255C	320000	170M2621	450FMM	-	6.9URD31D11A0450	A070URD30XXX0450
EMX3-0360C	238000	170M6010	-	HSJ400 **	6.9URD33D11A0630	A070URD33XXX0630
EMX3-0380C	320000	170M6011	400FMM *	-	6.9URD33D11A0800	A070URD33XXX0700
EMX3-0430C	320000	170M6011	400FMM*	-	6.9URD33D11A0800	A070URD33XXX0700
EMX3-0620C	1200000	170M6015	630FMM *	-	6.9URD33D11A1000	A070URD33XXX1000
EMX3-0650C	1200000	170M6015	630FMM *	-	6.9URD33D11A1000	A070URD33XXX1000
EMX3-0790C	2530000	170M6017	-	-	6.6URD33D11A1250	A070URD33XXX1250
EMX3-0930C	4500000	170M6019	-	-	6.6URD33D11A1400	A070URD33XXX1400
EMX3-1200C	4500000	170M6019	-	-	6.9URD233PLAF1800	A065URD33XXX1800
EMX3-1410C	6480000	170M6021	-	-	6.9URD233PLAF2200	-
EMX3-1600C	12500000	170M6018 *	-	-	6URD233PLAF2500	A050URD33XXX1400*

\* Two parallel connected fuses required per phase.  
 \*\* Two series connected fuses required per phase.  
 XXX Blade Type. Refer to Ferraz catalog for options.



**NOTE**

Adaptive Acceleration Control (XLR-8) controls the motor's speed profile, within the programmed time limit. This may result in a higher level of current than traditional control methods.

For applications using Adaptive Acceleration Control to soft stop the motor with stop times greater than 30 seconds, motor branch protection should be selected as follows:

- standard HRC line fuses: minimum 150% motor full load current
- motor rated line fuses: minimum rating 100/150% motor full load current
- motor control circuit breaker minimum long time setting: 150% motor full load current,
- motor control circuit breaker minimum short time setting: 400% motor full load current for 30 seconds

**3.7 Earth Terminal**

Earth terminals are located at the back of the soft starter.

- EMX3-0023B ~ EMX3-0220B have one terminal, on the input side.
- EMX3-0255C ~ EMX3-1600C have two terminals, one on the input side and one on the output side.

3.8 Schematic Diagrams

Internally bypassed models

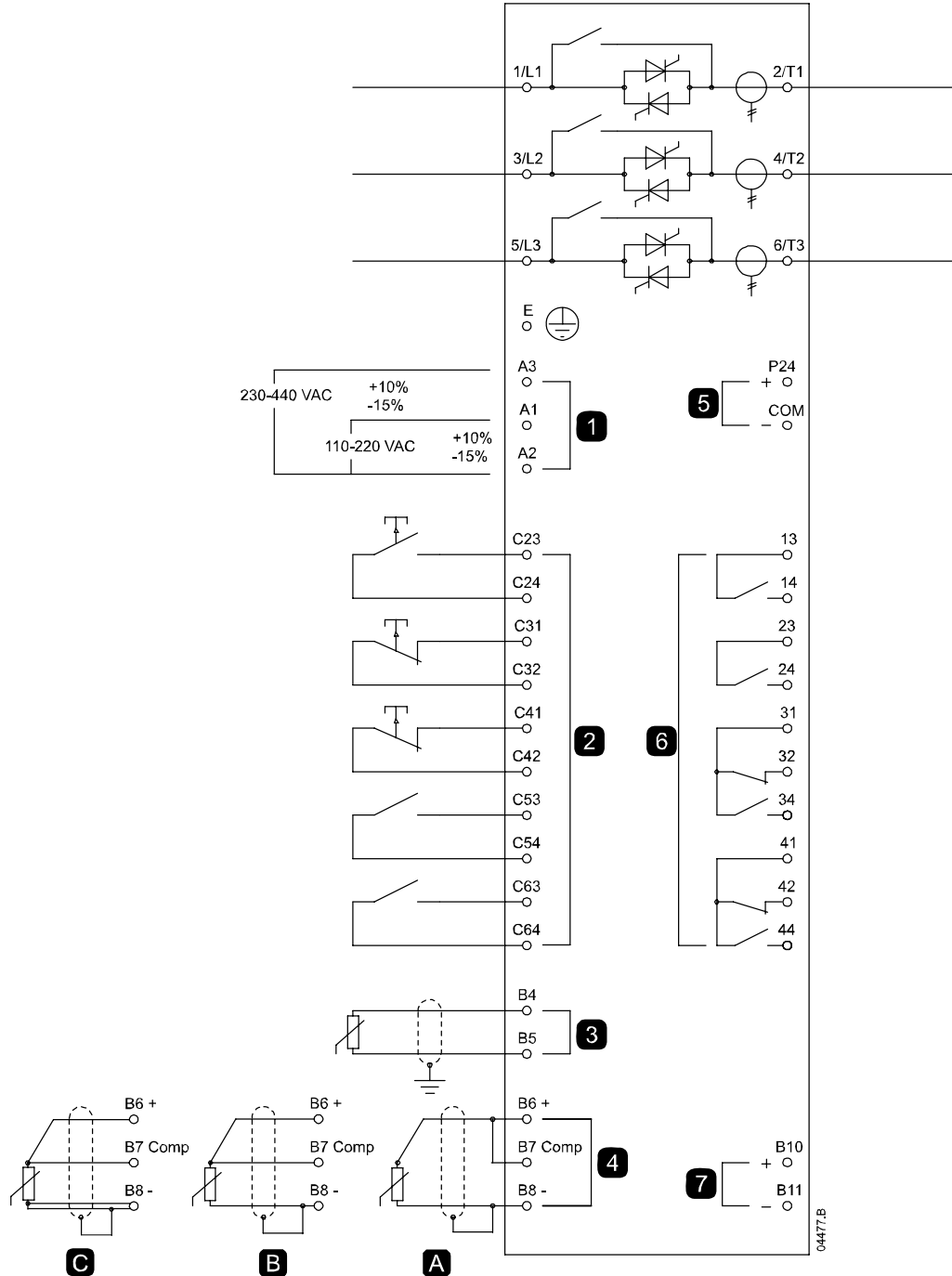

1	Control supply
2	Remote control inputs
3	Motor Thermistor input
4A	PT100 RTD input - 2 Wire
4B	PT100 RTD input - 3 Wire
4C	PT100 RTD input - 4 Wire
5	24 VDC output
6	Relay outputs
7	Analog output

C23-C24	Start
C31-C32	Stop
C41-C42	Reset
C53-C54	Programmable input A
C63-C64	Programmable input B
13-14	Relay A
23-24	Run relay output
31, 32, 34	Relay output B
41, 42, 44	Relay output C

Non-bypassed models

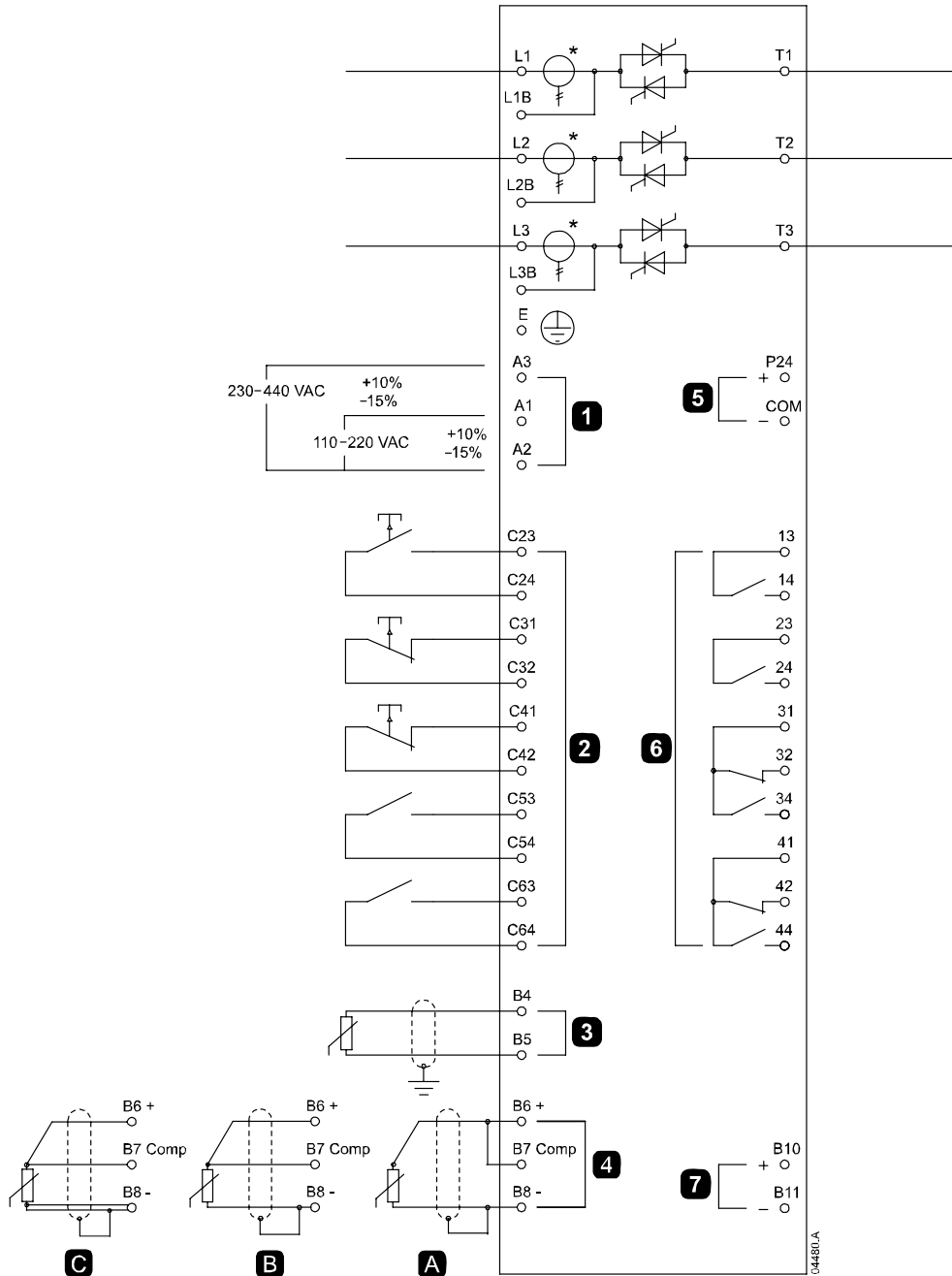

1	Control supply
2	Remote control inputs
3	Motor Thermistor input
4A	PT100 RTD input - 2 Wire
4B	PT100 RTD input - 3 Wire
4C	PT100 RTD input - 4 Wire
5	24 VDC output
6	Relay outputs
7	Analog output

C23-C24	Start
C31-C32	Stop
C41-C42	Reset
C53-C54	Programmable input A
C63-C64	Programmable input B
13-14	Relay A
23-24	Run relay output
31, 32, 34	Relay output B
41, 42, 44	Relay output C



**NOTE**  
 \* EMX3-0255C current transformers are located on the output. Bypass terminals are labelled T1B, T2B and T3B.

## Section 4 Keypad and Feedback

### 4.1 The Keypad

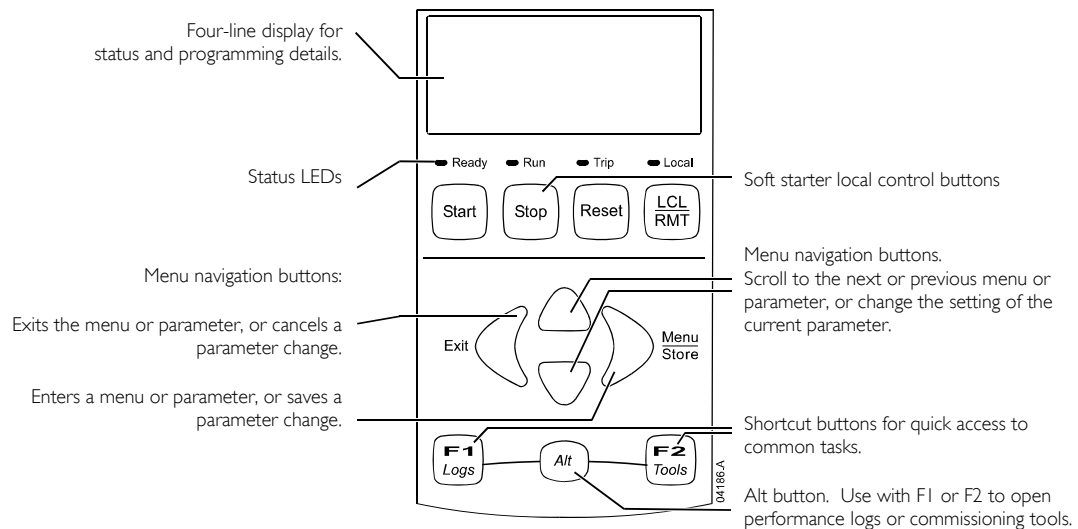

#### Removing and Replacing the Keypad

The keypad can be removed from the soft starter and mounted remotely on a panel using the remote mounting kit.

The keypad stores a backup copy of the parameters in the soft starter, so one keypad can be used to program multiple EMX3 starters.

The keypad is attached to the body of the soft starter by a DB9 serial connector and two screws. The screws are concealed behind a snap-on faceplate.

To remove the keypad:

1. On the EMX3-0023B ~ EMX3-0220B open the EMX3's door, on EMX3-0255C ~ EMX3-1600C remove the EMX3's front cover.
2. Insert a small screwdriver under the faceplate, between the air vents in the side of the starter, and use the screwdriver to lever the faceplate off the keypad.
3. Lift the faceplate off completely.

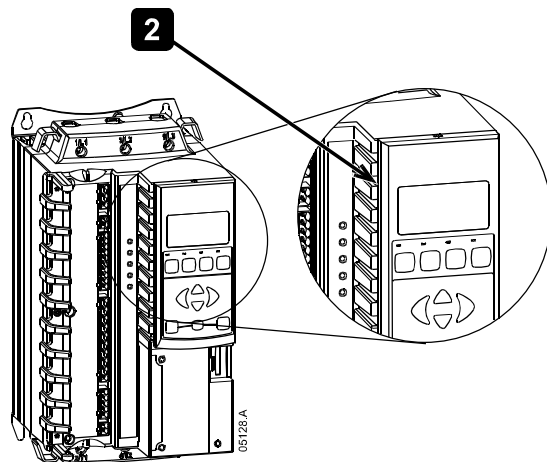

4. Remove the two screws holding the keypad in place.
5. Lift the keypad gently off the soft starter. Pull the keypad forwards, to avoid damaging the DB9 connector.

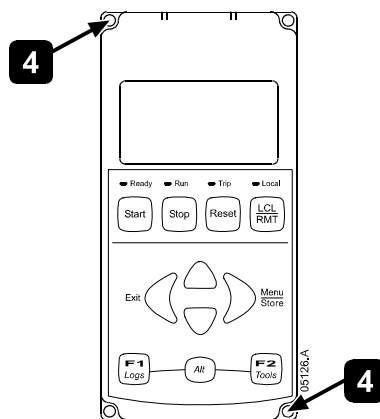

To replace the keypad:

1. Align the connector on the back of the keypad with the socket on the soft starter and push the keypad firmly into place. The keypad will be held in place by the connector and two locating nibs in the top right and bottom left corners.  
For temporary installation (eg during commissioning) it is not necessary to screw the keypad in place.
2. Replace the two screws holding the keypad in place.
3. Slide the curved bottom edge of the faceplate over the body of the keypad, then swing the top edge of the faceplate into place and press onto the keypad. The retaining tabs on the back of the faceplate will snap into place.

- **Synchronising the Keypad and the Starter**

When a keypad is connected to an EMX3, it synchronises its parameter settings with the settings in the soft starter.

Every time a different keypad is plugged into the starter, an acknowledgement is displayed.



The default action is to copy the parameter settings from the keypad to the soft starter. To change the action, use the ▲ and ▼ buttons. Press STORE to proceed.

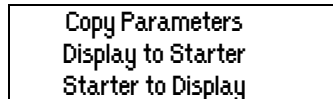

If any of the settings in the keypad are not valid for the starter, the keypad loads the default values.

## 4.2 Displays

The keypad displays a wide range of performance information about the soft starter. The top half of the screen shows real-time information on current or motor power (as selected in parameter 8D). Use the ▲ and ▼ buttons to select the information shown on the bottom half of the screen.

- Starter status
- Motor temperature
- Current
- Motor power
- Voltage
- Last start information
- Date and time



**NOTE**  
Screens shown here are with the default settings.

### Starter Status

The starter status screen shows details of the starter's operating status and motor current or power.

Ready	0000.0kW
M1 000%	

### Programmable screen

The EMX3's user-programmable screen can be configured to show the most important information for the particular application. Use parameters 8E to 8H to select which information to display.

0.0A	
Ready	
0 hrs	-- %

### Motor Temperature

The temperature screen shows which motor data set is in use, and the temperature of both motors as a percentage of total thermal capacity. If the EMX3 is configured for use on one motor, the temperature for the secondary motor (M2) will always show 0%.

0.0A	
Primary Motor Set	
> M1 000%	M2 000%

### Current

The current screen shows real-time line current on each phase. If the RTD and ground fault protection card is fitted, the screen will also show ground current.

0.0A		
Phase currents		
000.0A	000.0A	000.0A

### Motor Power

The motor power screen shows motor power (kW, HP and kVA) and power factor.

0.0A	
0000.0kW	0000HP
0000kVA	-. - pf

If the voltage measurement card is not installed, the motor power figures are calculated using the Mains Reference Voltage (parameter 8N).

### Last Start Information

The last start information screen shows details of the most recent successful start:

- start duration (seconds)
- maximum start current drawn (as a percentage of motor full load current)
- calculated rise in motor temperature

0.0A	
Last start	
010 s	
350 % FLC	Δ Temp 5%

## Date and Time

The date/time screen shows the current system date and time (24 hour format). For details on setting the date and time, refer to *Set Date and Time* in Section 5.1.

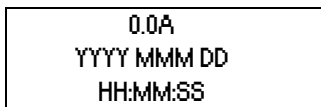

## Performance Graph

The performance graph provides a real-time display of operating performance. Use parameters 8I~8L to select which information to display.

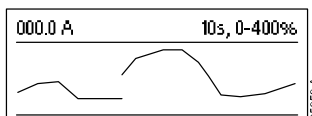

## SCR Conduction Bargraph

The SCR conduction bargraph shows the level of conduction on each phase.

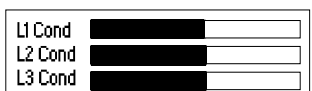

For internally bypassed models the SCRs are off during run.

## Menus

### Commissioning Menu

The Commissioning Menu provides access to commissioning and testing tools.

To open the Commissioning Menu, press **ALT** then **F2** (Tools) while viewing the metering screens.

To navigate through the Commissioning Menu:

- to scroll to the next or previous item, press the ▲ or ▼ button.
- to open an item for viewing, press the ► button.
- to return to the previous level, press the ◀ button.
- to close the Commissioning Menu, press ◀ repeatedly.

### Programming Menu

The Programming Menu lets you view and change programmable parameters that control how the EMX3 operates.

To open the Programming Menu, press the **MENU** button while viewing the monitoring screens.

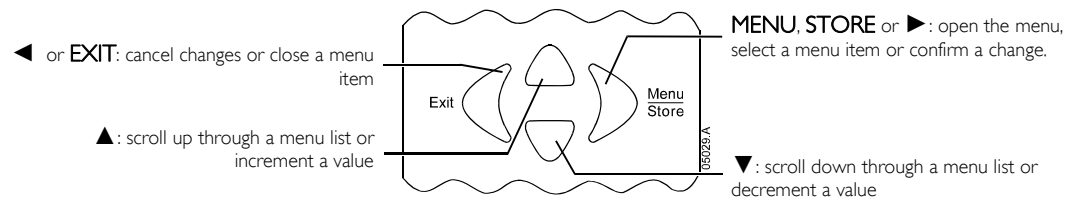

To navigate through the Programming Menu:

- to scroll through parameter groups, press the ▲ or ▼ button.
- to open a submenu, press the ► button.
- to view the parameters in a group, press the ► button.
- to return to the previous level, press the ◀ button.
- to close the Programming Menu, press ◀ repeatedly.

To change a parameter value:

- scroll to the appropriate parameter in the Programming Menu and press ► to enter edit mode.
- to alter the parameter setting, use the ▲ and ▼ buttons. Pressing ▲ or ▼ once will increase or decrease the value by one (1). If the button is held for longer than five seconds, the value will increase or decrease at a faster rate.
- to save changes, press **STORE**. The setting shown on the display will be saved and the keypad will return to the parameter list.
- to cancel changes, press **EXIT**. The keypad will ask for confirmation, then return to the parameter list without saving changes.
- to end edit mode, press **EXIT**. The keypad will return to the parameter list and any unsaved changes will be lost.

- **Logs Menu**

The Logs Menu provides information on events, trips and starter performance.

To open the Logs Menu, press **ALT** then **FI** (Logs) while viewing the metering screens.

To navigate through the Logs Menu:

- to open a log, press the ► button.
- to scroll through the entries in each log, press the ▲ and ▼ buttons.
- to view details of a log entry, press the ► button.
- to return to the previous level, press the ◀ button.
- to close the Logs Menu, press ◀ repeatedly.

**Section 5 Maintenance Tools**

**5.1 Commissioning Menu**

The Commissioning Menu provides access to commissioning and testing tools.

To open the Commissioning Menu, press **ALT** then **F2 (Tools)** while viewing the metering screens.

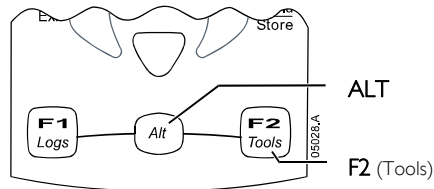

To navigate through the Commissioning Menu:

- to scroll to the next or previous item, press the ▲ or ▼ button.
- to open an item for viewing, press the ► button.
- to return to the previous level, press the ◀ button.
- to close the Commissioning Menu, press ◀ repeatedly.

**Set Date and Time**

To set the date and time:

1. Open the Commissioning Menu.
2. Scroll to the date/time screen.
3. Press the ► button to enter edit mode.
4. Press the ► button to select which part of the date or time to edit.
5. Use the ▲ and ▼ buttons to change the value.
6. To save changes, press the ► button repeatedly. The EMX3 will confirm the changes.  
To cancel changes, press the ◀ button repeatedly.

**Simulation Tools**

Software simulation functions let you test the soft starter's operation and control circuits without connecting the soft starter to mains voltage. The EMX3 has three simulation modes:

- Run simulation: simulates a motor starting, running and stopping to confirm that the soft starter and associated equipment have been installed correctly.
- Protection simulation: simulates activation of each protection mechanism to confirm that the soft starter and associated control circuits are responding correctly.
- Output signal simulation: simulates output signalling to confirm that outputs and associated control circuits are operating correctly.

The simulation tools are accessed via the Commissioning Menu. The simulations are only available when the soft starter is in Ready state, control voltage is available and the keypad is active.



**NOTE**

Access to the simulation tools is protected by the security access code.  
Default access code is 0000.

• **Run Simulation**

The run simulation simulates starting, running and stopping the motor. The run simulation is a safe method of confirming that the soft starter, external switchgear and control equipment have been installed and configured correctly.

You can end the simulation at any time by pressing **EXIT**. The keypad will return to the Commissioning Menu.

To use the run simulation:

- |                                                                                                                                                                                                 |                                                                                          |
|-------------------------------------------------------------------------------------------------------------------------------------------------------------------------------------------------|------------------------------------------------------------------------------------------|
| <ol style="list-style-type: none"> <li>1. Open the Commissioning Menu.</li> <li>2. Scroll to Run Simulation and press ►.</li> <li>3. Press <b>START</b> or activate the start input.</li> </ol> | <p>Run Simulation<br/>Ready<br/>Apply Start Signal</p>                                   |
| <ol style="list-style-type: none"> <li>4. If the Mains voltage is connected an error message is shown. Remove the Mains voltage and proceed to next step.</li> </ol>                            | <p>Run Simulation<br/><b>ATTENTION!</b><br/>Remove Mains Volts<br/>STORE to Continue</p> |
| <ol style="list-style-type: none"> <li>5. Press ►. The EMX3 simulates its pre-start checks and closes the main contactor (if installed). The Run LED flashes.</li> </ol>                        | <p>Run Simulation<br/>Pre-Start Checks<br/>STORE to Continue</p>                         |
| <ol style="list-style-type: none"> <li>6. Press ►. The EMX3 simulates starting. The Run LED flashes.</li> </ol>                                                                                 | <p>Run Simulation<br/>Starting X:XXs<br/>STORE to Continue</p>                           |
| <ol style="list-style-type: none"> <li>7. Press ►. The EMX3 simulates running. The Run LED stays on without flashing and the bypass contactors close.</li> </ol>                                | <p>Run Simulation<br/>Running<br/>Apply Stop Signal</p>                                  |
| <ol style="list-style-type: none"> <li>8. Press <b>STOP</b> or activate the stop input. The EMX3 simulates stopping. The Run LED flashes.</li> </ol>                                            | <p>Run Simulation<br/>Stopping X:XXs<br/>STORE to Continue</p>                           |
| <ol style="list-style-type: none"> <li>9. Press ► to finish the simulation and return to the Commissioning Menu. The Ready LED flashes.</li> </ol>                                              | <p>Run Simulation<br/>Stopped<br/>STORE to Continue</p>                                  |

• **Protection Simulation**

The EMX3 can simulate each different protection, in order to confirm that the soft starter is responding correctly and reporting the situation on the display and across the communication network.

To use the protection simulation:

- |                                                                                                                                                                                                                                                                                                                                                                                                                                                                                                                                                                                                |                                                 |
|------------------------------------------------------------------------------------------------------------------------------------------------------------------------------------------------------------------------------------------------------------------------------------------------------------------------------------------------------------------------------------------------------------------------------------------------------------------------------------------------------------------------------------------------------------------------------------------------|-------------------------------------------------|
| <ol style="list-style-type: none"> <li>1. Open the Commissioning Menu.</li> <li>2. Scroll to Protection Simulation and press ►.</li> <li>3. Use the ▲ and ▼ buttons to select the protection you want to simulate.</li> <li>4. Press ► to simulate the selected protection.</li> <li>5. The screen is displayed momentarily. The soft starter's response depends on the Protection Action setting (parameter group I 6).</li> <li>6. Press ◀ to return to the simulation list.</li> <li>7. Use ▲ or ▼ to select another simulation, or press ◀ to return to the Commissioning Menu.</li> </ol> | <p>0.0A<br/>Tripped<br/>Selected Protection</p> |
|------------------------------------------------------------------------------------------------------------------------------------------------------------------------------------------------------------------------------------------------------------------------------------------------------------------------------------------------------------------------------------------------------------------------------------------------------------------------------------------------------------------------------------------------------------------------------------------------|-------------------------------------------------|



**NOTE**

If the protection trips the soft starter, reset before simulating another protection. If the protection action is set to 'Warning or Log', no reset is required.

If the protection is set to 'Warning & Log', the warning message can be viewed only while the 'Menu/Store' button is pressed.

If the protection is set to 'Log only', nothing appears on the screen but will appear in the log.

• **Output Signal Simulation**

The keypad allows the user to simulate output signalling in order to confirm that the output relays are operating correctly.



**NOTE**

To test operation of the flags (motor temperature and low/high current), set an output relay to the appropriate function and monitor the relay's behaviour.

To use the signal simulation:

1. Open the Commissioning Menu.
2. Scroll to Output Signalling Simulation and press ►.
3. Use the ▲ and ▼ buttons to select a simulation, then press ►.
4. Use the ▲ and ▼ buttons to turn the signal on and off.  
To confirm correct operation, monitor the state of the output.

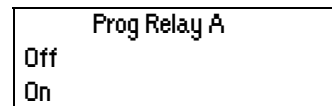

5. Press ◀ to return to the simulation list.

• **Analog Output Simulation**

The analog output simulation uses the ▲ and ▼ buttons to change the current at the analog output terminals.

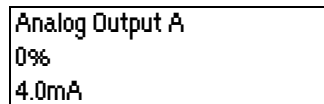

Attach a current measuring device to the analog output terminals. Use the ▲ or ▼ button to adjust the percentage value on the display. The current measuring device should indicate the same level of current as shown on the display.

If the input/output expansion card is fitted, the simulation can also be used to test the operation of Relays D, E, F and Analog Output B.

• **Temperature Sensors State**

This screen shows the state of the Motor Thermistors and RTD. If the RTD/Ground Fault expansion card is fitted, this will show the status of RTDs 2 ~ 7.

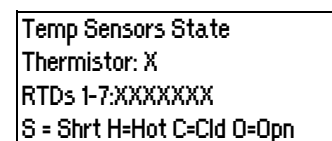

• **Digital I/O State**

Digital I/O State

This screen shows the current status of the Digital I/O in order. The screen shot shows Input C23-24 as open (0) Input C31~32 as closed (1). The outputs follow a similar pattern.

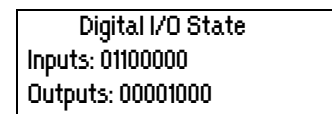

• Analog I/O State

Analog I/O State

This screen shows the current status of the Analog I/O

Analog I/O State  
 Input: ---- %  
 Output A: 04.0mA

**Thermal Model Reset**

The EMX3's advanced thermal modelling software constantly monitors the motor's performance. This allows the EMX3 to calculate the motor's temperature and ability to start successfully at any time. If the EMX3 is configured for use on two motors, each motor's temperature is modelled separately.

The thermal model for the active motor can be reset if required.

1. Open the Commissioning Menu.
2. Scroll to Reset Thermal Models and press ►.

Reset Thermal Models  
 M1 X%  
 M2 X%  
 Store to Reset

3. At the confirmation prompt, press **STORE** to confirm or **EXIT** to cancel the action.

Reset Thermal Models  
 Store/Exit

4. When the thermal model has been reset, the screen will display a confirmation message then return to the previous screen.



**WARNING**

The thermal models should only be reset when essential, e.g. in an emergency situation when the motor start must be started, even if this compromises protection.

**5.2 Logs Menu**

The Logs Menu provides information on events, trips and starter performance.

To open the Logs Menu, press **ALT** then **F1** (Logs) while viewing the metering screens.

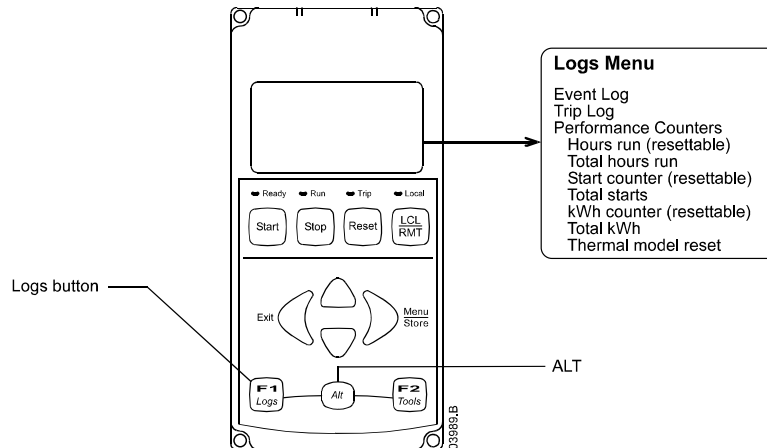

To navigate through the Logs Menu:

- to open a log, press the ► button.
- to scroll through the entries in each log, press the ▲ and ▼ buttons.
- to view details of a log entry, press the ► button.
- to return to the previous level, press the ◀ button.
- to close the Logs Menu, press ◀ repeatedly.

### Trip Log

The trip log stores details of the eight most recent trips, including the date and time the trip happened. Trip 1 is the most recent and trip 8 is the oldest stored trip.

To open the trip log:

1. Open the Logs Menu.
2. Scroll to trip log and press ►.
3. Use the ▲ and ▼ buttons to select a trip to view, and press ► to display details.

To close the log and return to the main display, press ◀ twice.

### Event Log

The event log stores time-stamped details of the starter's 99 most recent events (actions, warnings and trips), including the date and time of the event. Event 1 is the most recent and event 99 is the oldest stored event.

To open the event log:

1. Open the Logs Menu.
2. Scroll to event log and press ►.
3. Use the ▲ and ▼ buttons to select an event to view, and press ► to display details.
4. To close the log and return to the main display, press ◀ twice.

### Performance Counters

The performance counters store statistics on the starter's operation:

- Hours run (lifetime and since counter last reset)
- Number of starts (lifetime and since counter last reset)
- Motor kWh (lifetime and since counter last reset)
- Number of times the thermal model has been reset

The resettable counters (hours run, starts and motor kWh) can only be reset if the Adjustment Lock (parameter 15B) is set to Read & Write.

To view the counters:

1. Open the Logs Menu.
2. Scroll to counters and press ►.
3. Use the ▲ and ▼ buttons to scroll through the counters. Press ► to view details.
4. To reset a counter, press ► then press **STORE** to confirm the action.
5. To close the counter and return to the Logs Menu, press ◀.

## Section 6 Operation

### 6.1 Start, Stop and Reset Commands

The soft starter can be controlled in three ways:

- using the buttons on the keypad
- via remote inputs
- via a serial communication link

The **LCL/RMT** button controls whether the EMX3 will respond to local control (via the keypad) or remote control (via the remote inputs). The Local LED on the keypad is on when the soft starter is in local control mode and off when the soft starter is in remote control mode. The remote LED on the EMX3 is on when the soft starter is in Remote mode and off when in the Local mode.

Serial communication is always enabled in local control mode, and can be enabled or disabled in remote control mode (refer to parameter 6R).

The **STOP** button on the keypad is always enabled.

#### Using the EMX3 to Control a Motor

To soft start the motor, press the **START** button on the keypad or activate the Start remote input. The motor will start using the start mode selected in parameter 2A.

To stop the motor, press the **STOP** button on the keypad or activate the Stop remote input. The motor will stop using the stop mode selected in parameter 2H.

To emergency stop the motor, press the local **STOP** and **RESET** buttons at the same time. Alternatively, one of the programmable inputs can be configured for emergency stop (parameters 6A and 6F). The soft starter will remove power from the motor and open the main contactor, and the motor will coast to stop.

To reset a trip on the soft starter, press the **RESET** button on the keypad or activate the Reset remote input.



#### NOTE

XLR-8, Brake and Jog functions operate only with in-line connected motors.

### 6.2 Soft Start Methods

Soft starters offer a variety of methods for the control of motor starting. Each soft start method uses a different primary control parameter.

Soft Start Method	Parameter Controlled	Performance Parameters Influenced
Timed Voltage Ramp	Voltage	Start current, start torque, acceleration
Constant Current	Current	Start torque, acceleration
Torque Control	Torque	Start current, acceleration
Adaptive Acceleration Control	Acceleration	Start current, start torque

Best results are obtained by selecting the soft start method that directly controls the parameter of most importance for the application. Typically soft starters are used to limit motor start current, or the control load acceleration and/or deceleration. the EMX3 can be set to either Constant Current or XLR-8 Adaptive Acceleration Control.

To Control	Use
Motor Start Current	Constant Current
Motor/Load Acceleration or Deceleration	XLR-8 Adaptive Acceleration Control

**Constant Current**

Constant current is the traditional form of soft starting, which raises the current from zero to a specified level and keeps the current stable at that level until the motor has accelerated.

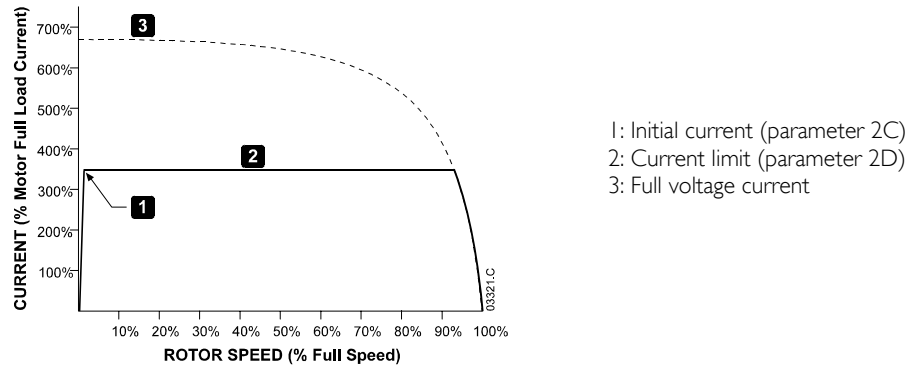

Constant current starting is ideal for applications where the start current must be kept below a particular level.

**Current Ramp**

Current ramp soft starting raises the current from a specified starting level (1) to a maximum limit (3), over an extended period of time (2).

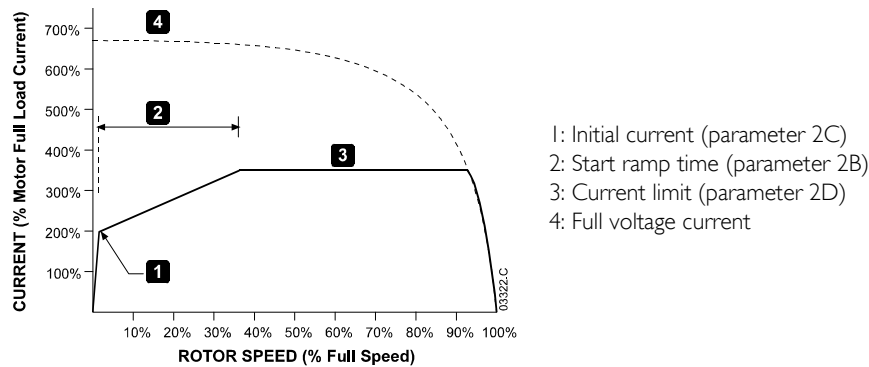

Current ramp starting can be useful for applications where:

- the load can vary between starts (for example a conveyor which may start loaded or unloaded). Set the initial current (parameter 2C) to a level that will start the motor with a light load, and the current limit (parameter 2D) to a level that will start the motor with a heavy load.
- the load breaks away easily, but starting time needs to be extended (for example a centrifugal pump where pipeline pressure needs to build up slowly).
- the electricity supply is limited (for example a generator set), and a slower application of load will allow greater time for the supply to respond.

**XLR-8 Adaptive Acceleration Control (starting)**

To use XLR-8 Adaptive Acceleration Control for the control of starting performance;

1. Select Adaptive Control from the Start Mode menu (parameter 2A)
2. Set the desired Start Ramp Time (parameter 2B)
3. Select the desired Adaptive Start Profile (parameter 2E)
4. Set a start Current Limit (parameter 2D) sufficiently high to allow a successful start. The first XLR-8 start will be a Constant Current start. This is required so that the EMX3 can learn the characteristics of the connected motor. This motor data is used by the EMX3 during subsequent XLR-8 Adaptive Acceleration Control starts.

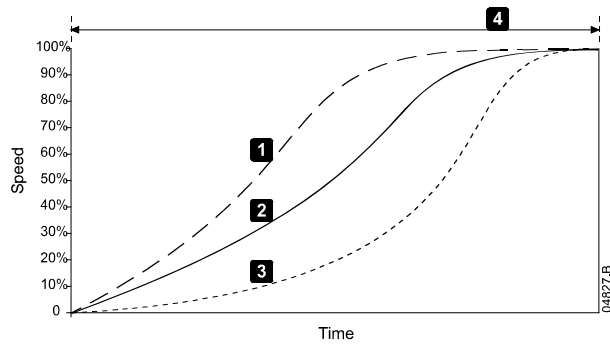

- Adaptive start profile (parameter 2E):
1. Early acceleration
  2. Constant acceleration
  3. Late acceleration
  4. Start ramp time (parameter 2B)



**NOTE**

XLR-8 will control the load according to the programmed profile. Start current will vary according to the selected acceleration profile and start time.

XLR-8 cannot start the motor faster than a direct on-line (DOL) start.

If replacing a motor connected to an EMX3 programmed for XLR-8 starting, or if the starter has been tested on a different motor prior to actual installation, it will be necessary for the EMX3 to learn the characteristics of the new motor. To force the EMX3 into learn mode, make an adjustment to parameter 2K Adaptive Control Gain as follows:

- If 2-K is at default setting of 75%, adjust to 76%.
- If 2-K is not at default setting of 75%, adjust to 75%.

**Kickstart**

Kickstart provides a short boost of extra torque at the beginning of a start, and can be used in conjunction with current ramp or constant current starting.

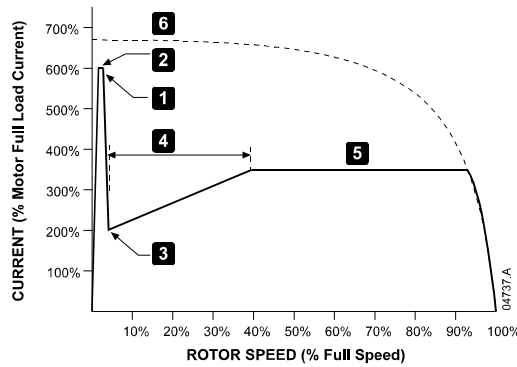

- 1: Kickstart level (parameter 2G)
- 2: Kickstart time (parameter 2F)
- 3: Initial current (parameter 2C)
- 4: Start ramp time (parameter 2B)
- 5: Current limit (parameter 2D)
- 6: Full voltage current

Kickstart can be useful to help start loads that require high breakaway torque but then accelerate easily (for example flywheel loads such as presses).

### 6.3 Stop Methods

Soft starters offer a variety of methods for the control of motor stopping.

Stop Method	Performance Result
Coast To Stop	Natural load run down
TVR Soft Stop	Extended run down time
Adaptive Acceleration Control	Extended run down time according to selected deceleration profile
Brake	Reduced run down time

Soft starters are often used in pumping applications to eliminate the damaging effects of fluid hammer. XLR-8 Adaptive Acceleration Control should be the preferred stop method for these applications.

#### Coast to Stop

Coast to stop lets the motor slow at its natural rate, with no control from the soft starter. The time required to stop will depend on the type of load.

#### TVR Soft Stop

Timed voltage ramp reduces the voltage to the motor gradually over a defined time. The load may continue to run after the stop ramp is complete.

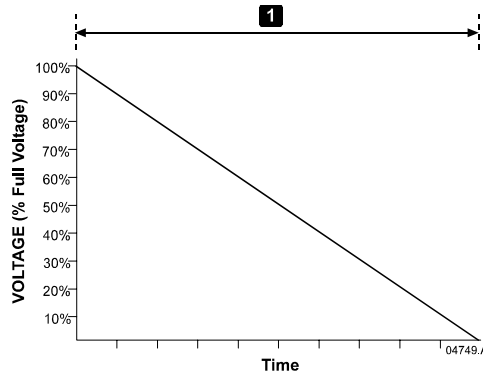

1: Stop time (parameter 2I)

Timed voltage ramp stopping can be useful for applications where the stop time needs to be extended, or to avoid transients on generator set supplies.

#### XLR-8 Adaptive Acceleration Control (Stopping)

To use XLR-8 Adaptive Acceleration Control for the control of stopping performance;

1. Select Adaptive Control from the Stop Mode menu (parameter 2H)
2. Set the desired Stop Time (parameter 2I)
3. Select the required Adaptive Stop Profile (parameter 2J)

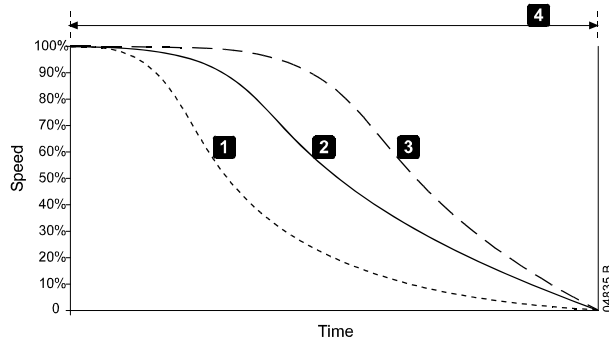

XLR-8 Adaptive stop profile (parameter 2J):

1. Early deceleration
2. Constant deceleration
3. Late deceleration
4. Stop ramp time (parameter 2B)



**NOTE**

Pump stopping: The hydraulic characteristics of pump systems vary considerably. This variation means the ideal deceleration profile and stop time will vary from application to application. The table below provides guidelines on selecting between XLR-8 deceleration profiles, however trials of the three XLR-8 deceleration profiles will identify the best profile for a given application.

Adaptive Stop Profile	Application
Late Deceleration	High head systems where even a small decrease in motor/pump speed results in a rapid transition between forward flow and reverse flow.
Constant Deceleration	Low to medium head, high flow applications where the fluid has high momentum.
Early Deceleration	Open pump systems where fluid must drain back through the pump without driving the pump in reverse.

The first XLR-8 stop will be a normal soft stop. This is required so that the EMX3 can learn the characteristics of the connected motor. This motor data is used by the EMX3 during subsequent XLR-8 adaptive acceleration control stops.



**NOTE**

XLR-8 will control the load according to the programmed profile. Stopping current will vary according to the selected deceleration profile and stop time.

XLR-8 cannot stop the motor faster than a coast to stop. Use Brake for shorter stopping times.

If replacing a motor connected to an EMX3 programmed for XLR-8 starting, or if the starter has been tested on a different motor prior to actual installation, it will be necessary for the EMX3 to learn the characteristics of the new motor. To force the EMX3 into learn mode, make an adjustment to parameter 2K Adaptive Control Gain as follows:

- If 2-K is at default setting of 75%, adjust to 76%.
- If 2-K is not at default setting of 75%, adjust to 75%.

**Brake**

Brake reduces the time the motor requires to stop. This is recommended for medium to low inertia loads. For high inertia loads soft braking is recommended.

- **Brake**

When brake is selected, the EMX3 uses DC injection to slow the motor.

The EMX3 braking:

- Does not require the use of a DC brake contactor
- Controls all three phases so that the braking currents and associated heating is evenly distributed through the motor.

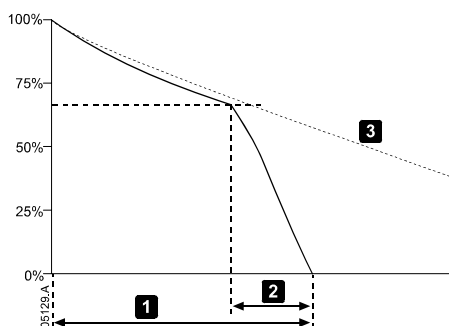

- 1: Stop time (parameter 2I)
- 2: Brake time (parameter 2M)
- 3: Coast to stop time

Braking has two stages:

1. Pre-brake: provides an intermediate level of braking to slow motor speed to a point where full brake can be operated successfully (approximately 70% speed).
2. Full brake: brake provides maximum braking torque but is ineffective at speeds greater than approximately 70%.

To configure the EMX3 for brake operation:

1. Set parameter 2I for the desired stopping time duration (1). This is the total braking time and must be set sufficiently longer than the brake time (parameter 2M) to allow the pre-braking stage to reduce motor speed to approximately 70%. If the stop time is too short, braking will not be successful and the motor will coast to stop.
2. Set Brake Time (parameter 2M) to approximately one quarter of the programmed Stop Time. This sets the time for the Full Brake stage (2).
3. Adjust the Brake Torque (parameter 2L) so that the desired stopping performance is achieved. If set too low, the motor will not stop completely and will coast to stop by the end of the braking period. If set too high, the motor will stop before the end of the brake time and the motor will suffer unnecessary heating which could result in damage.
4. In installations using an external zero-speed sensor (eg: applications with variable load during the braking cycle), please refer to "EMX3 Braking with external zero-speed sensing" (Application Note: 710-06356-00)



### NOTE

Brake operation causes motor heating. If you are using brake, enable the motor temperature check (parameter 4N) or allow sufficient restart delay (parameter 4M).

During braking an increased noise level from the motor may be audible. This is a normal part of motor braking.

## 6.4 Jog Operation

Jog runs the motor at reduced speed (approximately 11% of full running speed), to allow alignment of the load or to assist servicing.

The motor can be jogged in either forward or reverse direction. To activate jog operation, use either a programmable input or a shortcut key (refer to parameters 6A and 6F or 8B and 8C).

Jog is only available for the primary motor. Soft start and soft stop do not apply to jog operation.

If any other command is received when jogging the starter will stop and await a new command.

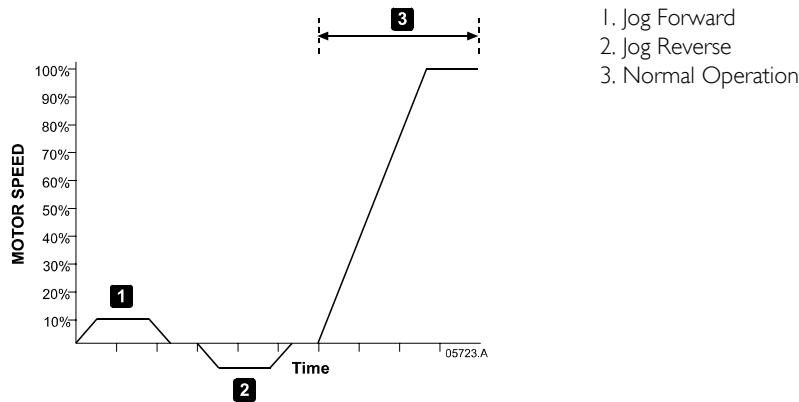

In some applications the available jog torque may not be sufficient to accelerate the motor as required. In these applications a customised forward jog profile can be programmed using secondary motor setting Start/Stop Modes 2 in parameter group 10. Please refer to "EMX3 Forward Jog" (Application Note: 710-06355-00).



### WARNING

Slow speed running is not intended for continuous operation due to reduced motor cooling.

## Section 7 Programming Menu

You can access the Programming Menu at any time, including while the soft starter is running. Any changes to the start profile take effect after the next start. All other changes take effect immediately.

The Programming Menu contains four sub-menus:

<b>Quick Setup</b>	Quick Setup guides you through the parameters required to configure the EMX3 for common applications. Quick Setup suggests a value for each parameter, but you can change these as required.
<b>Standard Menu</b>	The Standard Menu provides access to commonly used parameters, allowing you to configure the EMX3 to suit your application.
<b>Extended Menu</b>	The Extended Menu provides access to all the EMX3's programmable parameters, allowing experienced users to take advantage of advanced features.
<b>Load/Save Settings</b>	Load/Save Settings lets you save the current parameter settings to a file, load parameters from a previously saved file, or reset all parameters to default values.

### 7.1 Programming Menu

The Programming Menu lets you view and change programmable parameters that control how the EMX3 operates.

To open the Programming Menu, press the **MENU** button while viewing the monitoring screens.

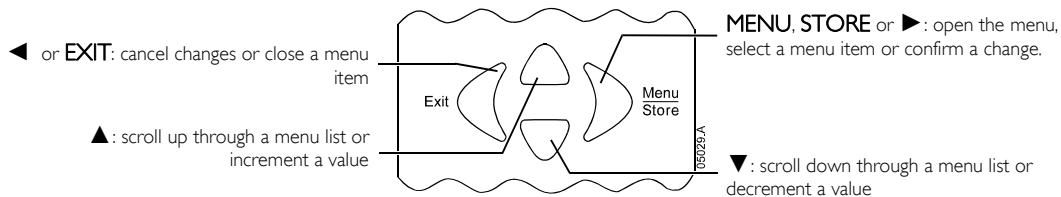

To navigate through the Programming Menu:

- to scroll through parameter groups, press the ▲ or ▼ button.
- to open a submenu, press the ▶ button.
- to view the parameters in a group, press the ▶ button.
- to return to the previous level, press the ◀ button.
- to close the Programming Menu, press ◀ repeatedly.

To change a parameter value:

- scroll to the appropriate parameter in the Programming Menu and press ▶ to enter edit mode.
- to alter the parameter setting, use the ▲ and ▼ buttons. Pressing ▲ or ▼ once will increase or decrease the value by one (1). If the button is held for longer than five seconds, the value will increase or decrease at a faster rate.
- to save changes, press **STORE**. The setting shown on the display will be saved and the keypad will return to the parameter list.
- to cancel changes, press **EXIT**. The keypad will ask for confirmation, then return to the parameter list without saving changes.
- to end edit mode, press **EXIT**. The keypad will return to the parameter list and any unsaved changes will be lost.

## 7.2 Adjustment Lock

You can lock the Programming Menu to prevent users from altering parameter settings. The adjustment lock can be turned on and off using parameter 15B.

To lock the programming menu:

1. Open the Programming Menu.
2. Open the Extended Menu.
3. Select 'Advanced'
4. Enter Access Code
5. Select Adjustment Lock.
6. Select and Store 'Read and Write'

If a user attempts to change a parameter value when the adjustment lock is active, an error message is displayed:

**Access Denied**  
**Adj Lock is On**

## 7.3 Access Code

Critical parameters in the Programming Menu (parameter group 15 and higher) are protected by a four-digit security access code, preventing unauthorised users from viewing or modifying parameter settings.

When a user attempts to enter a restricted parameter group, the keypad prompts for an access code. The access code is requested once for the programming session, and authorisation continues until the user closes the menu.

To enter the access code:

1. Open the Programming Menu.
2. Open the Extended Menu.
3. Select Advanced
4. Select Access Code.

Use the ◀ and ▶ buttons to select a digit, and the ▲ and ▼ buttons to change the value. When all four digits match your access code, press **STORE**. The keypad will display an acknowledgement message before continuing.

**Enter Access Code**  
\*\*\*\*

STORE

**Access Allowed**  
Supervisor

The simulation tools and counter resets are also protected by the security access code.

The default access code is 0000.

## 7.4 Quick Setup

The quick setup menu makes it easy to configure the EMX3 for common applications. The EMX3 selects the parameters relevant to the application and suggests a typical setting, and you can adjust each parameter to suit your exact requirements.

On the display the highlighted values are suggested values and the values indicated by a ▶ are the loaded values.

Always set parameter 1A *Motor FLC* to match the motor's nameplate full load current. The suggested value for motor FLC is the starter's minimum FLC.

Application	Parameter	Suggested value
Pump Centrifugal	Motor FLC Start Mode Start Ramp Time Current Limit Stop Mode Stop Time Adaptv Start Profile Adaptv Stop Profile	Adaptive Control 5 seconds 350% Adaptive Control 15 seconds Early Acceleration Late Deceleration
Pump Submersible	Motor FLC Start Mode Start Ramp Time Current Limit Stop Mode Stop Time Adaptv Start Profile Adaptv Stop Profile	Adaptive Control 5 seconds 350% Adaptive Control 5 seconds Early Acceleration Late Deceleration
Fan Damped	Motor FLC Start Mode Start Ramp Time Current Limit Adaptv Start Profile	Adaptive Control 15 seconds 350% Constant Acceleration
Fan Undamped	Motor FLC Locked Rotor Time Start Mode Start Ramp Time Current Limit Adaptv Start Profile Excess Start Time	20 seconds Adaptive Control 20 seconds 400% Constant Acceleration 30 seconds
Compressor Screw	Motor FLC Start Mode Start Ramp Time Current Limit Adaptv Start Profile	Adaptive Control 10 seconds 400% Constant Acceleration
Compressor Reciprocating	Motor FLC Start Mode Start Ramp Time Current Limit Adaptv Start Profile	Adaptive Control 10 seconds 450% Constant Acceleration
Conveyor	Motor FLC Start Mode Start Ramp Time Current Limit Stop Mode Stop Time Adaptive Start Profile Adaptive Stop Profile	Adaptive Control 15 seconds 400% Adaptive Control 5 seconds Late Acceleration Constant Acceleration
Crusher Rotary	Motor FLC Locked Rotor Time Start Mode Start Ramp Time Current Limit Adaptv Start Profile Excess Start Time	20 seconds Adaptive Control 20 seconds 400% Constant Deceleration 30 seconds
Crusher Jaw	Motor FLC Locked Rotor Time Start Mode Start Ramp Time Current Limit Adaptv Start Profile Excess Start Time	30 seconds Adaptive Control 30 seconds 450% Constant Acceleration 40 seconds

**7.5 Standard Menu**

The standard menu provides access to commonly used parameters, allowing the user to configure the EMX3 as required for the application. For details of individual parameters, refer to *Parameter Descriptions* in Section 7.8.

Parameter	Description	Default value
1 Motor Data-I	▶ 1A Motor Full Load Current	Model dependent
	◀	
2 Start/Stop Modes-I	▶ 2A Start Mode	Adaptive Control
	▶ 2B Start Ramp Time	10 s
	▶ 2C Initial Current	350%
	▶ 2D Current Limit	350%
	▶ 2H Stop Mode	Coast to Stop
	▶ 2I Stop Time	0m:00s
	◀	
3 Auto-Start/Stop	▶ 3A Auto-Start Type	Off
	▶ 3B Auto-Start Time	00h:01m
	▶ 3C Auto-Stop Type	Off
	▶ 3D Auto-Stop Time	00h:01m
4 Protection Settings	▶ 4A Excess Start Time	0m:20s
	▶ 4C Undercurrent	20%
	▶ 4D Undercurrent Dly	0m:05s
	▶ 4E Inst Overcurrent	400%
	▶ 4F Inst Overcmt Delay	0m:00s
	▶ 4G Phase Sequence	Any sequence
	◀	
6 Inputs	▶ 6A Input A Function	Motor Set Select
	▶ 6B Input A Name	Input Trip
	▶ 6C Input A Trip	Always Active
	▶ 6D Input A Trip Dly	0m:00s
	▶ 6E Input A Initial Dly	0m:00s
	▶ 6F Input B Function	Input Trip (N/O)
	▶ 6G Input B Name	Input Trip
	▶ 6H Input B Trip	Always Active
	▶ 6I Input B Trip Dly	0m:00s
	▶ 6J Input B Initial Dly	0m:00s
	◀	
7 Outputs	▶ 7A Relay A Function	Main Contactor
	▶ 7B Relay A On Delay	0m:00s
	▶ 7C Relay A Off Delay	0m:00s
	▶ 7D Relay B Function	Run
	▶ 7E Relay B On Delay	0m:00s
	▶ 7F Relay B Off Delay	0m:00s
	▶ 7G Relay C Function	Trip
	▶ 7H Relay C On Delay	0m:00s
	▶ 7I Relay C Off Delay	0m:00s
	▶ 7M Low Current Flag	50%
	▶ 7N High Current Flag	100%
	▶ 7O Motor Temp Flag	80%
	◀	

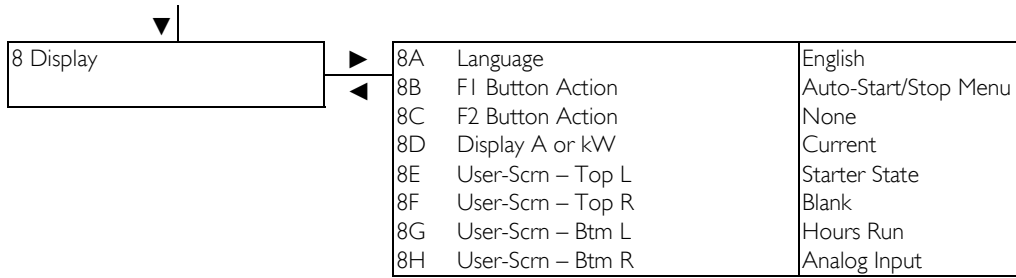

## 7.6 Extended Menu

The extended menu gives access to all of the EMX3's programmable parameters.

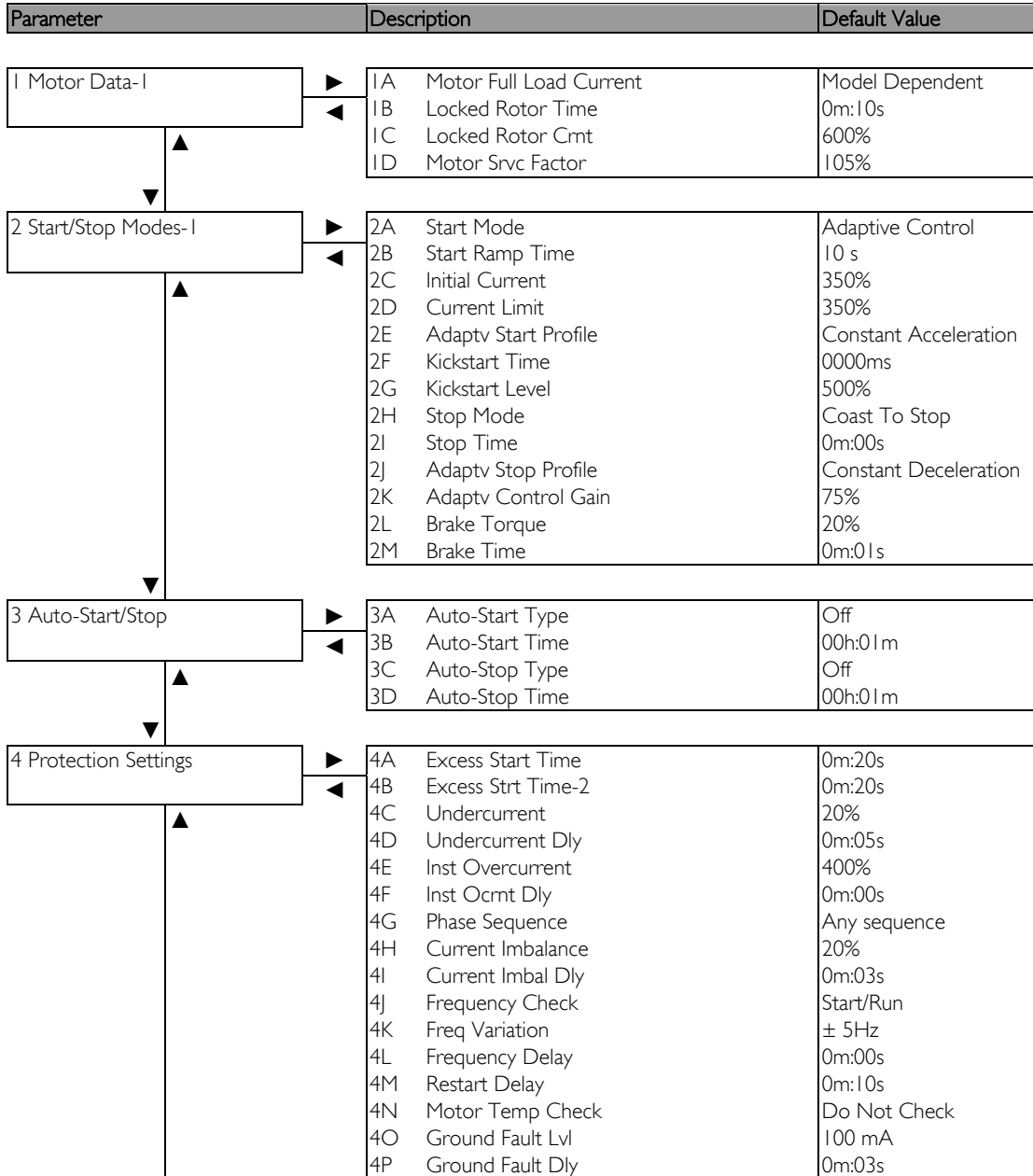

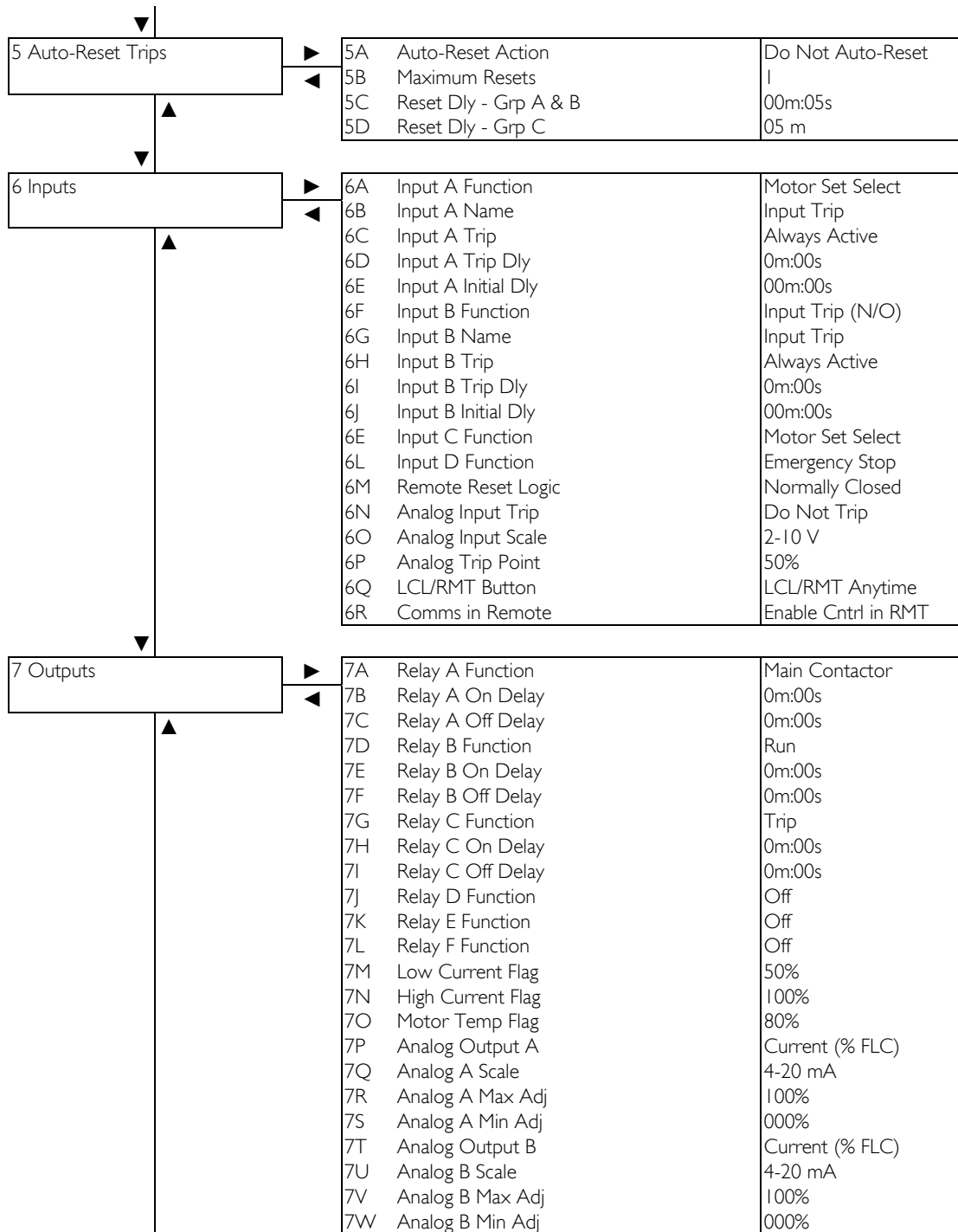

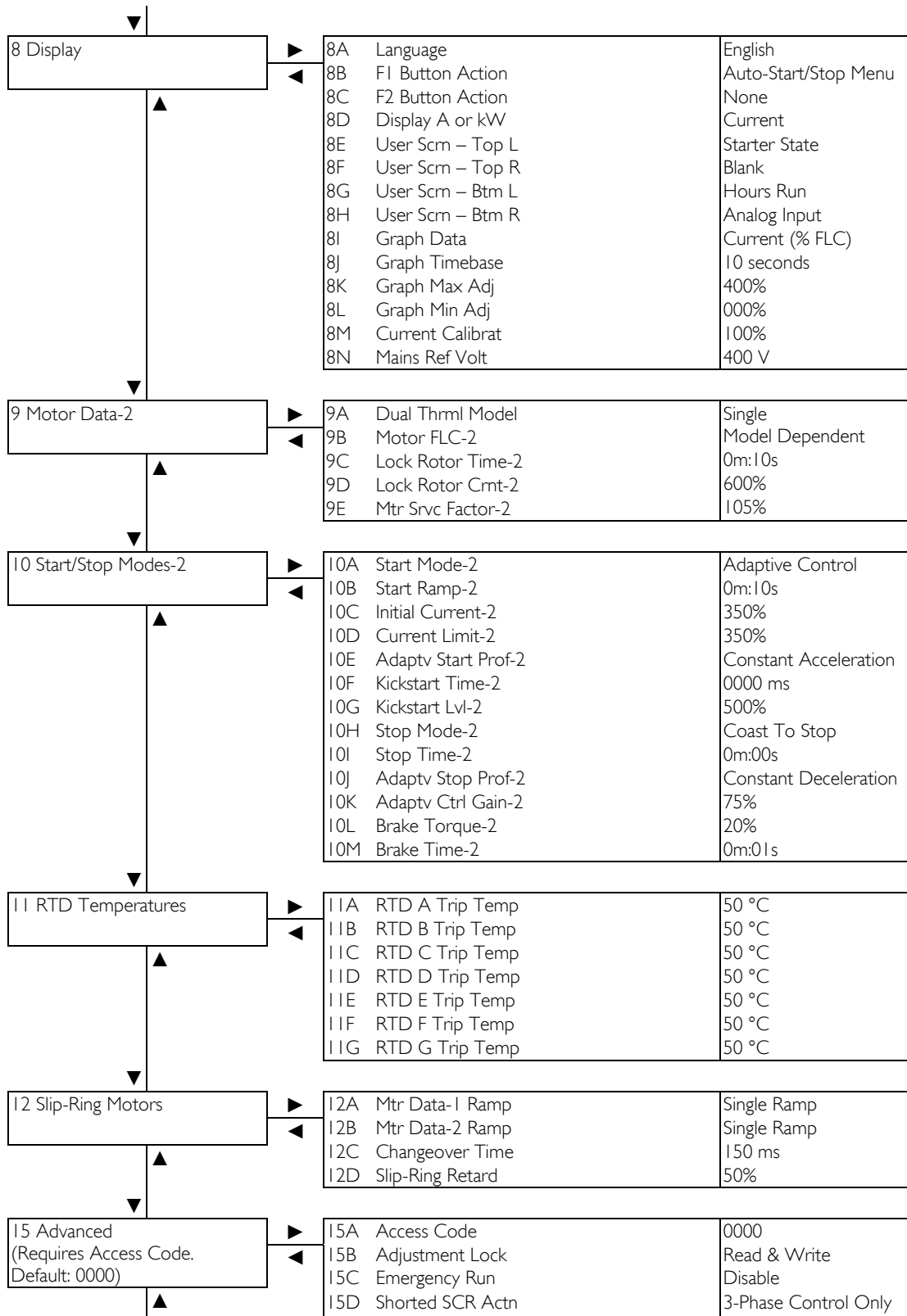

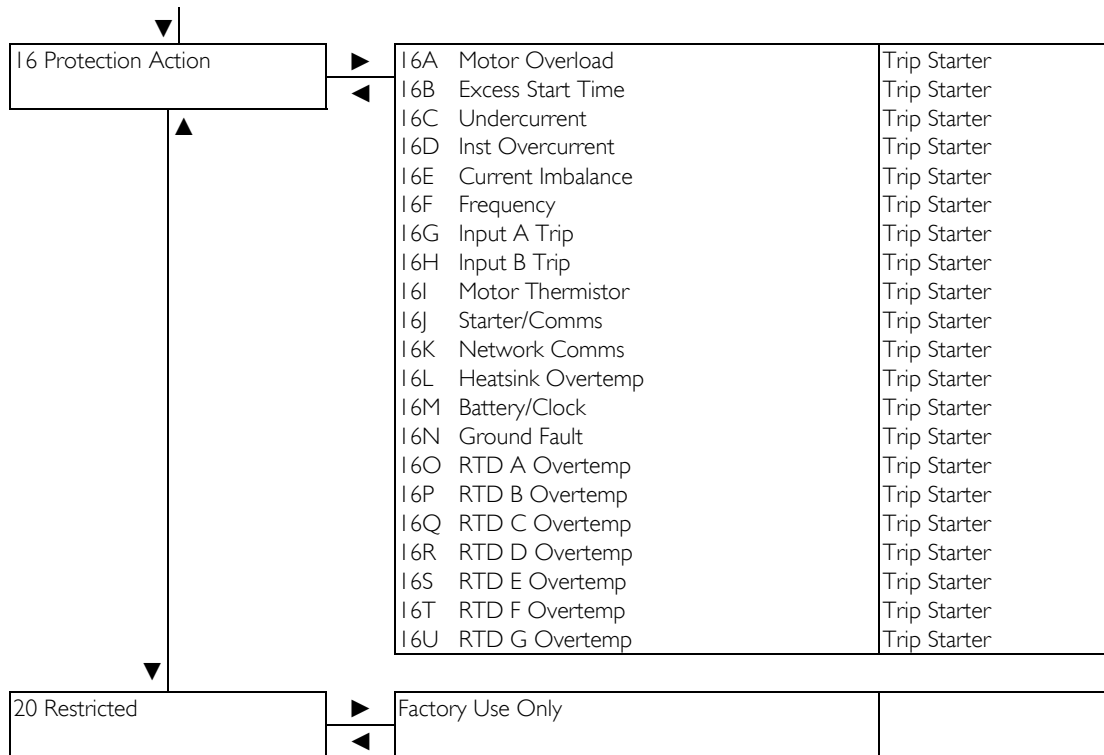

**7.7 Load/Save Settings**

The Load/Save Settings menu requires an access code and allows users to:

- Load the EMX3's parameters with default values
- Reload previously saved parameter settings from an internal file
- Save the current parameter settings to an internal file



**NOTE**

The saved files and current operating settings are stored in both the keypad and in the soft starter. The keypad will prompt you to synchronise the settings whenever it is plugged into a new EMX3.

In addition to the factory default values file, the EMX3 can store two user-defined parameter files. These files contain default values until a user file is saved.

To load or save parameter settings:

- 1 Open the Programming Menu.
- 2 Scroll to Load/Save Settings and press the ► button.
- 3 Use the ▼ button to select the required function, then press the ► button.
- 4 At the confirmation prompt, select YES to confirm or NO to cancel and then **STORE** to load/save the selection.

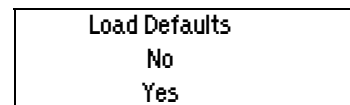
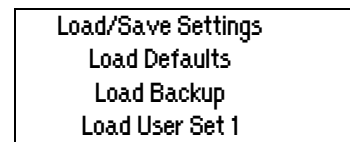

When the action has been completed, the screen will briefly display a confirmation message, then return to the status screens.

## 7.8 Parameter Descriptions

### I Motor Data-I

The parameters in Motor Data-I configure the soft starter to match the connected motor. These parameters describe the motor's operating characteristics and allow the soft starter to model the motor's temperature.

#### IA – Motor FLC

<b>Range:</b>	Model dependent
<b>Description:</b>	Motor Full Load Current matches the starter to the connected motor's full load current. Set to the full load current (FLC) rating shown on the motor nameplate.

#### IB – Locked Rotor Time

<b>Range:</b>	0:01 - 2:00 (minutes:seconds) (Default: 10 seconds)
<b>Description:</b>	Sets the maximum length of time the motor can run at locked rotor current from cold before reaching its maximum temperature. Set according to the motor datasheet.

#### IC – Locked Rotor Current

<b>Range:</b>	400% - 1200% FLC (Default: 600%)
<b>Description:</b>	Sets the locked rotor current of the connected motor, as a percentage of full load current. Set according to the motor datasheet.

#### ID – Motor Srvc Factor

<b>Range:</b>	100% - 130% (Default: 105%)
<b>Description:</b>	Motor Service Factor sets the motor service factor used by the thermal model. If the motor runs at full load current, it will reach 100%. Set according to the motor datasheet.

### 2 Start/Stop Modes-I

#### 2A – Start Mode

<b>Options:</b>	<i>Constant Current</i> <i>Adaptive Control</i> (Default)
<b>Description:</b>	Selects the soft start mode.

#### 2B – Start Ramp Time

<b>Range:</b>	1 - 180 (seconds) (Default: 10 seconds)
<b>Description:</b>	Sets the total start time for an XLR-8 adaptive acceleration control start or the ramp time for current ramp starting (from the initial current to the current limit).

#### 2C – Initial Current

<b>Range:</b>	100% - 600% FLC (Default: 350%)
<b>Description:</b>	Sets the initial start current level for current ramp starting, as a percentage of motor full load current. Set so that the motor begins to accelerate immediately after a start is initiated. If current ramp starting is not required, set the initial current equal to the current limit.

#### 2D – Current Limit

<b>Range:</b>	100% - 600% FLC (Default: 350%)
<b>Description:</b>	Sets the current limit for constant current and current ramp soft starting, as a percentage of motor full load current.

#### 2E Adaptv Start Profile

<b>Options:</b>	<i>Early Acceleration</i> <i>Constant Acceleration</i> (Default) <i>Late Acceleration</i>
<b>Description:</b>	Adaptive Start Profile selects which profile the EMX3 will use for an XLR-8 adaptive acceleration control soft start.

## 2F, 2G – Kickstart

---

### Parameter 2F – Kickstart Time

**Range:** 0 – 2000 (milliseconds) (Default: 0000 milliseconds)

**Description:** Sets the kickstart duration. A setting of 0 disables kickstart.

### Parameter 2G – Kickstart Level

**Range:** 100% - 700% FLC (Default: 500%)

**Description:** Sets the level of the kickstart current.



#### NOTE

Kickstart subjects the mechanical equipment to increased torque levels. Ensure the motor, load and couplings can handle the additional torque before using this feature.

## 2H – Stop Mode

---

**Options:** *Coast To Stop (Default)*  
*TVR Soft Stop*  
*Adaptv Control*  
*Brake*

**Description:** Selects the stop mode.

## 2I – Stop Time

---

**Range:** 0:00 - 4:00 (minutes:seconds) (Default: 0 seconds)

**Description:** Sets the time for soft stopping the motor using timed voltage ramp or XLR-8 adaptive acceleration control.  
If a main contactor is installed, the contactor must remain closed until the end of the stop time. Use the run output (terminals 23, 24) to control the main contactor.

## 2J – Adaptv Stop Profile

---

**Options:** *Early Deceleration*  
*Constant Deceleration (Default)*  
*Late Deceleration*

**Description:** Adaptive Stop Profile selects which profile the EMX3 will use for an XLR-8 adaptive acceleration control soft stop.

## 2K – Adaptv Control Gain

---

**Range:** 1% - 200% (Default: 75%)

**Description:** Adaptive Control Gain adjusts the performance of XLR-8 adaptive acceleration control.

## 2L, 2M – Brake

---

Brake uses DC injection to actively slow the motor.

### Parameter 2L Brake Torque

**Range:** 20 - 100% (Default: 20%)

**Description:** Sets the amount of brake torque the EMX3 will use to slow the motor.

### Parameter 2M Brake Time

**Range:** 1 - 30 (seconds) (Default: 1 second)

**Description:** Sets the duration for DC injection during a braking stop.



#### NOTE

Parameter 2M is used in conjunction with parameter 2I. Refer to *Section 6.3* for details.

### 3 Auto-Start/Stop

The EMX3 can be programmed to start and stop automatically, after a specified delay or at a specified time of day. Auto-start and auto-stop can be set separately.



#### NOTE

This function should not be used in conjunction with Remote and 2 wire control.

The soft starter will still accept start and stop commands from the keypad, remote inputs or serial communication network. To disable local or remote control, use parameter 6Q.

#### 3A, 3B – Auto-Start

##### Parameter 3A *Auto-Start Type*

<b>Options:</b>	<i>Off (Default)</i> <i>Timer</i>	The soft starter will not auto-start. The soft starter will auto-start after a delay from the next stop, as specified in parameter 3B.
	<i>Clock</i>	The soft starter will auto-start at the time programmed in parameter 3B.
<b>Description:</b>	Selects whether the soft starter will auto-start after a specified delay, or at a time of day.	

##### Parameter 3B *Auto-Start Time*

<b>Range:</b>	<i>00:01 - 24:00</i> (Default: 1 minute)
<b>Description:</b>	Sets the time for the soft starter to auto-start, in 24 hour clock format.

#### 3C, 3D – Auto-Stop

##### Parameter 3C *Auto-Stop Type*

<b>Options:</b>	<i>Off (Default)</i> <i>Timer</i>	The soft starter will not auto-stop. The soft starter will auto-stop after a delay from the next start, as specified in parameter 3D.
	<i>Clock</i>	The soft starter will auto-stop at the time programmed in parameter 3D.
<b>Description:</b>	Selects whether the soft starter will auto-stop after a specified delay, or at a time of day.	

##### Parameter 3D *Auto-Stop Time*

<b>Range:</b>	<i>00:01 - 24:00</i> (Default: 1 minute)
<b>Description:</b>	Sets the time for the soft starter to auto-stop, in 24 hour clock format.

### 4 Protection Settings

These parameters determine when the soft starter's protection mechanisms will activate. The activation point for each protection mechanism can be set to suit the installation.

The soft starter responds to protection events by tripping, warning, or writing the event to the event log. The response is determined by the Protection Action settings (parameter group 16). The default response is a trip.



#### NOTE

The protection settings are vital for safe operation of the soft starter and motor. Defeating the protection may compromise the installation and should only be done in the case of emergency.

#### 4A, 4B – Excess Start Time

Excess start time is the maximum time the EMX3 will attempt to start the motor. If the motor does not reach full speed within the programmed limit, the starter will trip. Set for a period slightly longer than required for a normal healthy start. A setting of 0 disables excess start time protection.

<b>Range:</b>	<i>0:00 - 4:00</i> (minutes:seconds) (Default: 20 seconds)
<b>Description:</b>	Parameter 4A sets the time for the primary motor and parameter 4B (Excess Strt Time-2) sets the time for the secondary motor.

**4C, 4D – Undercurrent**

---

The EMX3 can be configured to trip if the average current of all three phases drops below a specified level while the motor is running.

Parameter 4C *Undercurrent*

**Range:** 0% - 100% (Default: 20%)

**Description:** Sets the trip point for undercurrent protection, as a percentage of motor full load current. Set to a level between the motor's normal working range and the motor's magnetising (no load) current (typically 25% to 35% of full load current). A setting of 0% disables undercurrent protection.

Parameter 4D *Undercurrent Dly*

**Range:** 0:00 - 4:00 (minutes:seconds) (Default: 5 seconds)

**Description:** Slows the EMX3's response to undercurrent, avoiding trips due to momentary fluctuations.

**4E, 4F – Instantaneous Overcurrent**

---

The EMX3 can be configured to trip if the average current of all three phases exceeds a specified level while the motor is running.

Parameter 4E *Inst Overcurrent*

**Range:** 80% - 600% FLC (Default: 400%)

**Description:** Sets the trip point for instantaneous overcurrent protection, as a percentage of motor full load current.

Parameter 4F *Inst Ocrmt Delay*

**Range:** 0:00 - 1:00 (minutes:seconds) (Default: 0 seconds)

**Description:** Slows the EMX3's response to overcurrent, avoiding trips due to momentary overcurrent events.

**4G – Phase Sequence**

---

**Range:** Any sequence (Default)  
Positive only  
Negative only

**Description:** Selects which phase sequences the soft starter will allow at a start. During its pre-start checks, the starter examines the sequence of the phases at its input terminals and trips if the actual sequence does not match the selected option.

**4H, 4I – Current Imbalance**

---

The EMX3 can be configured to trip if the currents on the three phases vary from each other by more than a specified amount. The imbalance is calculated as the difference between the highest and lowest currents on all three phases, as a percentage of the highest current.

Current imbalance detection is desensitised by 50% during starting and soft stopping.

Parameter 4H *Current Imbalance*

**Range:** 10% - 50% (Default: 20%)

**Description:** Sets the trip point for current imbalance protection.

Parameter 4I *Current Imbal Dly*

**Range:** 0:00 - 4:00 (minutes:seconds) (Default: 3 seconds)

**Description:** Slows the EMX3's response to current imbalance, avoiding trips due to momentary fluctuations.

#### 4J, 4K, 4L – Frequency Trip

The EMX3 monitors mains frequency throughout operation, and can be configured to trip if the frequency varies beyond a specified tolerance.

##### Parameter 4J *Frequency Check*

**Range:** *Do Not Check*  
*Start Only*  
*Start/Run (Default)*  
*Run Only*

**Description:** Determines when the starter will monitor for a frequency trip.

##### Parameter 4K *Freq Variation*

**Range:**  $\pm 2$  Hz  
 $\pm 5$  Hz (Default)  
 $\pm 10$  Hz  
 $\pm 15$  Hz

**Description:** Selects the soft starter's tolerance for frequency variation.



##### NOTE

Running a motor outside its specified frequency for long periods can cause damage and premature failure.

##### Parameter 4L *Frequency Delay*

**Range:** *0:00 - 4:00* (minutes:seconds) (Default: *0 seconds*)

**Description:** Slows the EMX3's response to frequency disturbances, avoiding trips due to momentary fluctuations.



##### NOTE

If the mains frequency drops below 35 Hz, the starter will trip immediately.

#### 4M – Restart Delay

**Range:** *00:01 - 60:00* (minutes:seconds) (Default: *10 seconds*)

**Description:** The EMX3 can be configured to force a delay between the end of a stop and the beginning of the next start. During the restart delay period, the display shows the time remaining before another start can be attempted.



##### NOTE

The restart delay is measured from the end of each stop. Changes to the restart delay setting take effect after the next stop.

#### 4N – Motor Temp Check

**Range:** *Do Not Check (Default)*  
*Check*

**Description:** Selects whether the EMX3 will verify the motor has sufficient thermal capacity for a successful start. The soft starter compares the motor's temperature with the temperature rise from the last motor start and only operates if the motor is cool enough to start successfully.

**4O, 4P – Ground Fault Lvl**

The EMX3 can be configured to trip if ground fault exceeds a specified level while the motor is running. Ground fault is a dynamic trip based on phase current measurements every half-cycle.

Parameter 4O *Ground Fault Lvl*

**Range:** 20 mA - 50 A (21 steps) (Default: 100mA)

**Description:** Sets the trip point for ground fault protection.

Parameter 4P *Ground Fault Trip Dly*

**Range:** 0:01 - 4:00 (minutes:seconds) (Default: 3 seconds)

**Description:** Slows the EMX3's response to ground fault variation, avoiding trips due to momentary fluctuations.



**NOTE**

Ground fault protection is only available if the RTD and ground fault protection card is fitted.

**5 Auto-Reset Trips**

The EMX3 can be programmed to automatically reset certain trips, which can help minimise operating downtime. Trips are divided into three categories for auto-reset, depending on the risk to the soft starter:

Group	
A	Current Imbalance
	Phase loss
	Power loss
	Mains frequency
B	Undercurrent
	Instantaneous overcurrent
	Input A trip
	Input B trip
C	Motor overload
	RTD temperature trips
	Motor thermistor
	Starter overtemperature

Other trips cannot be automatically reset.

**5A – Auto-Reset Action**

**Options:** *Do Not Auto-Reset* (Default)  
*Reset Group A*  
*Reset Group A & B*  
*Reset Group A, B & C*

**Description:** Selects which trips can be auto-reset.

**5B – Maximum Reset**

**Range:** 1 - 5 (Default: 1)

**Description:** Sets how many times the soft starter will auto-reset, if it continues to trip. The reset counter increases by one each time the soft starter auto-resets, and decreases by one after each successful start/stop cycle.

### 5C, 5D – Auto-Reset Delay

The EMX3 can be configured to wait before auto-resetting a trip. Separate delays can be set for trips in Groups A and B, or in Group C.

#### Parameter 5C *Reset Dly Grp A & B*

**Range:** 00:05 - 15:00 (minutes:seconds) (Default: 5 seconds)

**Description:** Sets the delay for Group A and Group B trips.

#### Parameter 5D *Reset Dly Grp C*

**Range:** 5 - 60 (minutes) (Default: 5 minutes)

**Description:** Sets the delay for Group C trips.

## 6 Inputs

The EMX3 has two programmable inputs, which allow remote control of the soft starter. If required, two extra inputs are available on the input/output expansion card.

### 6A – Input A Function

<b>Options:</b>	<i>Motor Set Select</i> (Default)	The EMX3 can be configured with two separate sets of motor data. The primary motor data is programmed using parameters 1A to 2-M. The secondary motor data is programmed using parameters 9A to 2-M. To use the secondary motor data, parameter 6A must be set to Motor Set Select and C53-C54 must be closed when a start command is given. The EMX3 checks which motor data to use at a start, and will use that motor data for the entire start/stop cycle.
	<i>Input Trip (N/O)</i>	Input A can be used to trip the soft starter. When parameter 6A is set to Input Trip (N/O), a closed circuit across C53-C54 trips the soft starter (refer to parameters 6C, 6D, 6E).
	<i>Input Trip (N/C)</i>	When parameter 6A is set to Input Trip (N/C), an open circuit across C53-C54 trips the soft starter (refer to parameters 6C, 6D, 6E).
	<i>Local/Remote Select</i>	Input A can be used to select between local and remote control, instead of using the <b>LCL/RMT</b> button on the keypad. Selecting this option disables the <b>LCL/RMT</b> button, and the soft starter will ignore any Local/Remote select command from the serial communications network. An open circuit across the input selects local control and a closed circuit selects remote control. To use Input A to select between local and remote control, parameter 6Q must be set to Button Always Active or Button Active When Off.
	<i>Emergency Run</i>	In emergency run the soft starter continues to run until stopped, ignoring all trips and warnings (refer to parameter 15C for details). Closing the circuit across C53-C54 activates emergency run. Opening the circuit ends emergency run and the EMX3 stops the motor.
	<i>Emergency Stop</i>	The EMX3 can be commanded to emergency stop the motor, ignoring the soft stop mode set in parameter 2H. When the circuit across C53-C54 is opened, the soft starter allows the motor to coast to stop.
	<i>Jog Forward</i>	Activates jog operation in a forward direction.
	<i>Jog Reverse</i>	Activates jog operation in reverse direction.
<b>Description:</b>	Selects the function of Input A.	

## 6B – Input A Name

---

<b>Options:</b>	<i>Input Trip</i> (Default)	<i>No Flow</i>
	<i>Low Pressure</i>	<i>Emergency Stop</i>
	<i>High Pressure</i>	<i>Controller</i>
	<i>Pump Fault</i>	<i>PLC</i>
	<i>Low Level</i>	<i>Vibration Alarm</i>
	<i>High Level</i>	

**Description:** Selects a message for the keypad to display when Input A is active.

## 6C, 6D, 6E – Input A Trip

---

### Parameter 6C *Input A Trip*

<b>Options:</b>	<i>Always Active</i> (Default)	A trip can occur at any time when the soft starter is receiving power.
	<i>Operating Only</i>	A trip can occur while the soft starter is running, stopping or starting.
	<i>Run Only</i>	A trip can only occur while the soft starter is running.

**Description:** Selects when an input trip can occur.

### Parameter 6D *Input A Trip Dly*

**Range:** 0:00 - 4:00 (minutes:seconds) (Default: 0 seconds)

**Description:** Sets a delay between the input activating and the soft starter tripping.

### Parameter 6E *Input A Initial Dly*

**Range:** 00:00 - 30:00 (minutes:seconds) (Default: 0 seconds)

**Description:** Sets a delay before an input trip can occur, after the soft starter has entered the state selected in 6C.

## 6F, 6G, 6H, 6I, 6J – Input B Trip

---

Parameters 6F~6J configure the operation of Input B, in the same way as parameters 6A~6E configure Input A. Refer to Input A for details.

- 6F *Input B Function* (Default: *Input Trip N/O*)
- 6G *Input B Name*
- 6H *Input B Trip*
- 6I *Input B Trip Dly*
- 6J *Input B Initial Dly*

## 6E, 6L – Inputs C and D

---

Parameters 6E and 6L select the function of Inputs C and D. Refer to parameter 6A for details.

Inputs C and D are only available if the input/output expansion card has been installed.

<b>Options:</b>	<i>Motor Set Select</i> (Default for Input C)
	<i>Local/Remote Select</i>
	<i>Emergency Run</i>
	<i>Emergency Stop</i> (Default for Input D)

## 6M – Remote Reset Logic

---

<b>Options:</b>	<i>Normally Closed (N/C)</i> (Default)
	<i>Normally Open (N/O)</i>

**Description:** Selects whether the EMX3's remote reset input (terminals C41, C42) is normally open or normally closed.

### 6N, 6O, 6P – Analog Input

---

An analog input can be fitted to the EMX3 if required. An external device can activate the analog input to trip the soft starter in response to external conditions.

#### Parameter 6N *Analog Input Trip*

**Options:**        *Do Not Trip* (Default)  
                       *Trip High*  
                       *Trip Low*

**Description:**    Selects the soft starter's response to the analog input signal.

#### Parameter 6O *Analog Input Scale*

**Options:**        *0-10 V* (Default)  
                       *2-10 V*

**Description:**    Configures the analog input's scale.

#### Parameter 6P *Analog Trip Point*

**Range:**            *0% - 100%* (Default:50%)

**Description:**    Sets the signal level at which an analog input trip will occur, as a percentage of the maximum signal on the input.

### 6Q – LCL/RMT Button

---

<b>Options:</b>	<i>LCL/RMT Anytime</i> (Default) <i>LCL/RMT When Off</i> <i>Local Control Only</i> <i>Remote Control Only</i>	<b>LCL/RMT</b> button is always enabled. <b>LCL/RMT</b> button is enabled when the starter is off. All remote inputs are disabled. Local control buttons ( <b>START</b> , <b>RESET</b> , <b>LCL/RMT</b> ) are disabled.
-----------------	------------------------------------------------------------------------------------------------------------------------	----------------------------------------------------------------------------------------------------------------------------------------------------------------------------------------------------------------------------------

**Description:**    The Local/Remote button selects when the **LCL/RMT** button can be used to switch between local and remote control, and enables or disables the local control buttons and remote control inputs. The **STOP** button on the keypad is always enabled.



#### CAUTION

The **STOP** button on the keypad is always enabled. When using two-wire remote control, the soft starter will restart immediately if the remote start input is still active.

### 6R – Comms in Remote

---

**Options:**        *Disable Ctrl in RMT*  
                       *Enable Ctrl in RMT* (Default)

**Description:**    Selects whether the starter will accept Start, Stop and Reset commands from the serial communication network when in Remote mode. The Force Comms Trip, Local/Remote Control and Test Start commands are always enabled.

## 7 Outputs

The EMX3 has three programmable outputs, which can be used to signal different operating conditions to associated equipment. Three additional outputs are available on the input/output expansion card.

### 7A – Relay A Function

<b>Options:</b>	<i>Off</i>	Relay A is not used.
	<i>Main Contactor (Default)</i>	The relay closes when the EMX3 receives a start command, and remains closed as long as the motor is receiving voltage.
	<i>Run</i>	The relay closes when the starter changes to run state.
	<i>Trip</i>	The relay closes when the starter trips.
	<i>Warning</i>	The relay closes when the starter issues a warning.
	<i>Low Current Flag</i>	The relay closes when the low current flag activates (refer to parameter <i>7M Low Current Flag</i> ).
	<i>High Current Flag</i>	The relay closes when the high current flag activates (refer to parameter <i>7N High Current Flag</i> ).
	<i>Motor Temp Flag</i>	The relay closes when the motor temperature flag activates (refer to parameter <i>7O Motor Temperature Flag</i> ).
	<i>Input A Trip</i>	The relay closes when Input A activates to trip the soft starter.
	<i>Input B Trip</i>	The relay closes when Input B activates to trip the soft starter.
	<i>Motor Overload</i>	The relay closes when the starter trips on Motor Overload.
	<i>Current Imbalance</i>	The relay closes when the starter trips on Current Imbalance.
	<i>Undercurrent</i>	The relay closes when the starter trips on Undercurrent.
	<i>Inst Overcurrent</i>	The relay closes when the starter trips on Instantaneous Overcurrent.
	<i>Frequency</i>	The relay closes when the starter trips on Frequency.
	<i>Ground Fault</i>	The relay closes when the starter trips on Ground Fault.
	<i>Heatsink Overtemp</i>	The relay closes when the starter trips on Heatsink Overtemperature.
	<i>Phase Loss</i>	The relay closes when the starter trips on Phase Loss.
	<i>Motor Thermistor</i>	The relay closes when the starter trips on Motor Thermistor.
	<i>Changeover Contactor</i>	The relay closes when the high rotor resistance current ramp has reached full voltage, allowing use with a slip-ring motor.
<b>Description:</b>	Selects the function of Relay A (normally open).	

### 7B, 7C – Relay A Delays

The EMX3 can be configured to wait before opening or closing Relay A.

#### Parameter 7B *Relay A On Delay*

**Range:** 0:00 - 5:00 (minutes:seconds) (Default: 0 seconds)

**Description:** Sets the delay for closing Relay A.

#### Parameter 7C *Relay A Off Delay*

**Range:** 0:00 - 5:00 (minutes:seconds) (Default: 0 seconds)

**Description:** Sets the delay for re-opening Relay A.

## 7D~7L – Output Relays B, C, D, E, F

Parameters 7D~7L configure the operation of Relays B, C, D, E and F in the same way as parameters 7A~7C configure Relay A. Refer to Relay A for details.

Relay B is a changeover relay.

- 7D *Relay B Function* (Default: Run)
- 7E *Relay B On Delay*
- 7F *Relay B Off Delay*

Relay C is a changeover relay.

- 7G *Relay C Function* (Default: Trip)
- 7H *Relay C On Delay*
- 7I *Relay C Off Delay*

Relays D, E and F are only available if the input/output expansion card has been installed. These relays do not support on or off delays and do not support 'Changeover Contactor' function. Relay D is normally closed, relays E and F are normally open.

- 7J *Relay D Function* (Default: Off)
- 7K *Relay E Function* (Default: Off)
- 7L *Relay F Function* (Default: Off)

## 7M, 7N – Low Current Flag and High Current Flag

The EMX3 has low and high current flags to give early warning of abnormal operation. The current flags can be configured to indicate an abnormal current level during operation, between the normal operating level and the undercurrent or instantaneous overcurrent trip levels. The flags can signal the situation to external equipment via one of the programmable outputs. The flags clear when the current returns within the normal operating range by 10% of the programmed motor full load current.

### Parameter 7M *Low Current Flag*

**Range:** 1% - 100% FLC (Default: 50%)

**Description:** Sets the level at which the low current flag operates, as a percentage of motor full load current.

### Parameter 7N *High Current Flag*

**Range:** 50% - 600% FLC (Default: 100%)

**Description:** Sets the level at which the high current flag operates, as a percentage of motor full load current.

## 7O – Motor Temp Flag

The EMX3 has a motor temperature flag to give early warning of abnormal operation. The flag can indicate that the motor is operating above its normal operating temperature but lower than the overload limit. The flag can signal the situation to external equipment via one of the programmable outputs.

**Range:** 0% - 160% (Default: 80%)

**Description:** Sets the level at which the motor temperature flag operates, as a percentage of the motor's thermal capacity.

## 7P, 7Q, 7R, 7S – Analog Output A

The EMX3 has an analog output, which can be connected to associated equipment to monitor motor performance. If required, a second analog output is available on the input/output expansion card.

### Parameter 7P Analog Output A

<b>Options:</b>	<i>Current (% FLC)</i> (Default) <i>Motor Temp (%)</i> <i>Motor kW (%)</i> <i>Motor kVA (%)</i> <i>Motor pf</i> <i>Voltage (% Mains)</i>	Current as a percentage of motor full load current. Motor temperature as a percentage of the motor service factor (calculated by the soft starter's thermal model). Motor kilowatts. 100% is motor FLC (parameter 1A) multiplied by line voltage (measured voltage if the voltage measurement card is installed, otherwise reference voltage (parameter 8N)). Power factor is assumed to be 1.0 for the reference value, but the motor kilowatt value is calculated using measured power factor. Motor kilovolt amperes. 100% is motor FLC (parameter 1A) multiplied by line voltage (measured voltage if the voltage measurement card is installed, otherwise reference voltage (parameter 8N)). Motor power factor, measured by the soft starter. Line voltage, measured by the soft starter (this information is only available if the voltage measurement option is installed).
-----------------	---------------------------------------------------------------------------------------------------------------------------------------------------------	----------------------------------------------------------------------------------------------------------------------------------------------------------------------------------------------------------------------------------------------------------------------------------------------------------------------------------------------------------------------------------------------------------------------------------------------------------------------------------------------------------------------------------------------------------------------------------------------------------------------------------------------------------------------------------------------------------------------------------------------------------------------------------------------------------------------------------------------------------------------------------------------------

**Description:** Selects which information will be reported via analog output A.

### Parameter 7Q Analog A Scale

<b>Options:</b>	<i>0-20 mA</i> <i>4-20 mA</i> (Default)
-----------------	--------------------------------------------

**Description:** Selects the range of the output.

### Parameter 7R Analog A Max Adj

**Range:** *0% - 600%* (Default: 100%)

**Description:** Calibrates the upper limit of the analog output to match the signal measured on an external current measuring device.

### Parameter 7S Analog A Min Adj

**Range:** *0% - 600%* (Default: 0%)

**Description:** Calibrates the lower limit of the analog output to match the signal measured on an external current measuring device.

## 7T, 7U, 7V, 7W – Analog Output B

Parameters 7T~7W configure the operation of analog output B, in the same way as parameters 7P~7S configure analog output A. Refer to analog output A for details.

Output B is only available if the input/output expansion card has been installed.

## 8 Display

These parameters allow the keypad to be tailored to individual users' requirements.

### 8A – Language

<b>Options:</b>	<i>English</i> (Default) <i>Chinese</i>
-----------------	--------------------------------------------

**Description:** Selects which language the keypad will use to display messages and feedback.

### 8B, 8C – F1 and F2 Button Action

<b>Options:</b>	<i>None</i> <i>Auto-Start/Stop Menu</i> (Default) <i>Jog Forward</i> <i>Jog Reverse</i>
-----------------	--------------------------------------------------------------------------------------------------

**Description:** Selects the function of the **F1** and **F2** buttons on the keypad.

## 8D – Display A or kW

<b>Options:</b>	<i>Current</i> (Default) <i>Motor kW</i>
<b>Description:</b>	Selects whether the EMX3 will display current (amperes) or motor kilowatts on the main monitoring screen.

## 8E, 8F, 8G, 8H – User-Programmable Screen

<b>Options:</b>	<i>Blank</i>	Displays no data in the selected area, allowing long messages to be shown without overlapping.
	<i>Starter State</i> (Default)	The starter's operating state (starting, running, stopping or tripped). Only available for 'Top L' & 'Btm L'
	<i>Motor Current</i>	The average current measured on three phases.
	<i>Motor pf</i>	The motor's power factor, measured by the soft starter.
	<i>Mains Frequency</i>	The average frequency measured on three phases.
	<i>Motor kW</i>	The motor's running power in kilowatts.
	<i>Motor HP</i>	The motor's running power in horsepower.
	<i>Motor Temp</i>	The motor's temperature, calculated by the thermal model.
	<i>kWh</i>	The number of kilowatt hours the motor has run via the soft starter.
	<i>Hours Run</i>	The number of hours the motor has run via the soft starter.
	<i>Analog Input</i>	The level of analog input A (refer to parameters 6N~6P).
	<i>Mains Voltage</i>	The average voltage measured on three phases (this option is only available if the voltage measurement option is installed).

**Description:** Selects which four items will be displayed on the programmable monitoring screen. By default, the screen shows starter state, hours run and analog input.

- 8E *User Scm Top L* (Default: Starter State)
- 8F *User Scm Top R* (Default: Blank)
- 8G *User Scm Btm L* (Default: Hours Run)
- 8H *User Scm Btm R* (Default: Analog Input)

## 8I, 8J, 8K, 8L – Performance Graphs

The EMX3 has a real-time performance graph to report the behaviour of critical operating parameters.

Parameter 8I *Graph Data*

<b>Options:</b>	<i>Current (% FLC)</i> (Default)	Current as a percentage of motor full load current.
	<i>Motor Temp (%)</i>	Motor temperature as a percentage of the motor service factor (calculated by the soft starter's thermal model).
	<i>Motor kW (%)</i>	Motor kilowatts. 100% is motor FLC (parameter 1A) multiplied by line voltage (measured voltage if the voltage measurement card is installed, otherwise reference voltage (parameter 8N)). Power factor is assumed to be 1.0 for the reference value, but the motor kilowatt value is calculated using measured power factor.
	<i>Motor kVA (%)</i>	Motor kilovolt amperes. 100% is motor FLC (parameter 1A) multiplied by line voltage (measured voltage if the voltage measurement card is installed, otherwise reference voltage (parameter 8N)).
	<i>Motor pf</i>	Motor power factor, measured by the soft starter.
	<i>Voltage (% Mains)</i>	Line voltage, measured by the soft starter (this information is only available if the voltage measurement option is installed).

**Description:** Selects which information the graph will display.

Parameter 8J *Graph Timebase*

**Options:** 10 seconds (Default)  
 30 seconds  
 1 minute  
 5 minutes  
 10 minutes  
 30 minutes  
 1 hour

**Description:** Sets the graph time scale. The graph will progressively replace the old data with new data.

Parameter 8K *Graph Max Adj*

**Range:** 0% – 600% (Default: 400%)

**Description:** Adjusts the upper limit of the performance graph.

Parameter 8L *Graph Min Adj*

**Range:** 0% – 600% (Default: 0%)

**Description:** Adjusts the lower limit of the performance graph.

## 8M – Current Calibrat

**Range:** 85% - 115% (Default: 100%)

**Description:** Motor Current Calibration calibrates the soft starter's current monitoring circuits to match an external current metering device. Use the following formula to determine the necessary adjustment:

$$\text{Calibration (\%)} = \frac{\text{Current shown on soft starter display}}{\text{Current measured by external device}} \quad 03336.B$$

eg 102% =  $\frac{66 \text{ A}}{65 \text{ A}}$

## 8N – Mains Ref Volt

**Range:** 100 – 690 V (Default: 400V)

**Description:** Sets the nominal mains voltage for the keypad's monitoring functions, if the voltage measurement card is not installed. Parameter 8N is used to calculate motor kilowatts and kilovolt amperes (kVA) but does not affect the EMX3's motor control or protection.

## 9 Motor Data-2

The EMX3 can support two different starting and stopping motor data sets.

- To use the EMX3 with two separate motors (such as a duty-standby configuration), use parameter 9A to select dual thermal modelling and configure parameters 9B~9E to suit the second motor.
- To use the EMX3 with two different motor data sets for the same motor (for dual speed motors or applications where starting conditions may vary), use parameter 9A to select a single thermal model, and configure the starting and stopping profiles as required in parameters 10A~10G. The soft starter will ignore parameters 9B~9E and will use settings from the primary motor.

To select the secondary motor data set, a programmable input must be configured to parameter set selection (parameters 6A and 6F) and the input must be active when the soft starter receives a start signal.



**NOTE**

You can only choose which motor data set to use while the soft starter is stopped.

## 9A ~ 9E – Secondary Motor Settings

Refer to Motor Data-1 (parameters 1A~1D) for details.

### Parameter 9A *Dual Thml Model*

**Options:**        *Single* (Default)  
                      *Dual*

**Description:**    Activates dual thermal modelling. The dual thermal model is required only if the EMX3 is controlling two physically separate motors.

### Parameter 9B *Motor FLC-2*

**Range:**            *Model dependent*

**Description:**    Sets the secondary motor's full load current.

### Parameter 9C *Locked Rotor Time-2*

**Range:**            *0:01 - 2:00*(minutes:seconds) (Default: 10 seconds)

**Description:**    Sets the secondary motor's locked rotor time.

### Parameter 9D *Locked Rotor Cmt-2*

**Range:**            *400% - 1200% FLC* (Default: 600%)

**Description:**    Sets the secondary motor's locked rotor current.

### Parameter 9E *Motor Svc Factor-2*

**Range:**            *100% - 130% FLC* (Default: 105%)

**Description:**    Sets the secondary motor's service factor.

## 10 Start/Stop Modes-2

### 10A ~ 10M – Start/Stop-2

Refer to Start/Stop Modes-1 (parameters 2A~2N) for details.

### Parameter 10A *Start Mode-2*

**Options:**        *Constant Current*  
                      *Adaptive Control* (Default)

**Description:**    Selects the start mode for the secondary motor.

### Parameter 10B *Start Ramp Time-2*

**Range:**            *1 - 180*(seconds) (Default: 10 seconds)

**Description:**    Sets the total start time for an XLR-8 adaptive acceleration control start or the ramp time for current ramp starting (from the initial current to the current limit).

### Parameter 10C *Initial Crmt-2*

**Range:**            *100% - 600%* (Default: 350%)

**Description:**    Sets the initial start current level for current ramp or constant current starting.

### Parameter 10D *Current Limit-2*

**Range:**            *100% - 600% FLC* (Default: 350%)

**Description:**    Sets the current limit for constant current starting.

### Parameter 10E *Adptv Start Prof-2*

**Options:**        *Early Acceleration*  
                      *Constant Acceleration* (Default)  
                      *Late Acceleration*

**Description:**    Selects the start profile for an XLR-8 adaptive acceleration control soft start.

### Parameter 10F *Kickstart Time-2*

**Range:**            *0 - 2000*(milliseconds) (Default: 0000 milliseconds)

**Description:**    Sets the kickstart duration.

Parameter 10G Kickstart Lvl-2

**Range:** 100% - 700% FLC (Default: 500%)  
**Description:** Sets the level of the kickstart current.

Parameter 10H Stop Mode-2

**Options:** Coast to Stop (Default)  
 TVR Soft Stop  
 Adaptive Control  
 Brake  
**Description:** Selects the stop mode for the secondary motor.

Parameter 10I Stop Time-2

**Range:** 0:00 - 4:00 (minutes:seconds) (Default: 0 seconds)  
**Description:** Sets the stop time.

Parameter 10J Adptv Stop Prof-2

**Options:** Early Deceleration  
 Constant Deceleration (Default)  
 Late Deceleration  
**Description:** Selects the stop profile for an XLR-8 adaptive acceleration control stop.

Parameter 10K Adptv Ctrl Gain-2

**Range:** 1% - 200% (Default: 75%)  
**Description:** Adjusts the performance of an XLR-8 adaptive acceleration control.

Parameter 10L Brake Torque-2

**Range:** 20% - 100% (Default: 20%)  
**Description:** Sets the amount of brake torque the EMX3 will use to slow the motor.

Parameter 10M Brake Time-2

**Range:** 1 - 30 (seconds) (Default: 1 second)  
**Description:** Sets the duration for DC injection during a braking stop.

## 11 RTD Temperatures

The EMX3 has one PT100 RTD input and can be fitted with another six RTD inputs by using the RTD and ground fault protection card. The inputs can trip the soft starter when the temperature exceeds a specified point, and different trip temperatures can be set for each input.

The RTD inputs B ~ G are only available if the RTD and ground fault protection card have been installed.

**Range:** 50 - 250 °C (Default: 50 °C)  
**Description:** Sets the trip points for the RTD inputs.

- 11A RTD A Trip Temp
- 11B RTD B Trip Temp
- 11C RTD C Trip Temp
- 11D RTD D Trip Temp
- 11E RTD E Trip Temp
- 11F RTD F Trip Temp
- 11G RTD G Trip Temp

## I2 Slip-Ring Motors

These parameters allow the soft starter to be configured for use with a slip-ring motor.

### I2A, I2B – Mtr Data-1 and Mtr Data-2 Ramp

<b>Options:</b>	<i>Single Ramp</i> (Default) <i>Dual Ramp</i>
<b>Description:</b>	Selects whether to use a single or dual current ramp profile for soft starting. Set to single ramp for non-slip ring induction motors, or dual ramp for slip-ring induction motors. Parameter I2A selects the ramp configuration for the primary motor and parameter I2B selects the ramp configuration for the secondary motor.

### I2C – Changeover Time

<b>Range:</b>	100 - 500 (milliseconds) (Default: 150 milliseconds)
<b>Description:</b>	Sets the delay between the rotor resistance relay closing and the low resistance current ramp starting. Set so that the contactor has enough time to close, but the motor does not slow down. Parameter I2C only applies if parameter I2A or I2B <i>Motor Ramp Configuration</i> is set to dual ramp, and an output relay is set to changeover contactor.

### I2D – Slip-Ring Retard

<b>Range:</b>	10% - 90% (Default: 50%)
<b>Description:</b>	Sets the level of conduction while the rotor resistor closes, as a percentage of full conduction. Set so that no current pulse occurs, but the motor retains enough speed to start correctly.

## I5 Advanced

### I5A – Access Code

<b>Range:</b>	0000 - 9999 (Default: 0000)
<b>Description:</b>	Sets the access code to enter the simulation tools and counter resets or the restricted section of the Programming Menu (parameter group I5 and higher). Use the ◀ and ▶ buttons to select which digit to alter and use the ▲ and ▼ buttons to change the value.

### I5B – Adjustment Lock

<b>Options:</b>	<i>Read &amp; Write</i> (Default) <i>Read Only</i>	Allows users to alter parameter values in the Programming Menu. Prevents users altering parameter values in the Programming Menu. Parameter values can still be viewed.
<b>Description:</b>	Selects whether the keypad will allow parameters to be changed via the Programming Menu.	



#### NOTE

Changes to the Adjustment Lock setting take effect only after the Programming Menu has been closed.

### I5C – Emergency Run

---

**Options:** *Disable* (Default)  
*Enable*

**Description:** Selects whether the soft starter will permit emergency run operation. In emergency run, the soft starter will start (if not already running) and continue to operate until emergency run ends, ignoring stop commands and trips. Emergency run is controlled using a programmable input (parameters 6A and 6F).

### I5D – Shorted SCR Actn

---

**Options:** *3-Phase Control only* (Default)  
*PowerThrough*

**Description:** Selects whether the soft starter will allow PowerThrough operation. For critical applications this allows the soft starter to control the motor with two-phase control, if the soft starter is damaged on one phase. A shorted SCR trip must occur and be reset for PowerThrough to operate.



#### CAUTION

PowerThrough uses a two-phase soft start technology and additional care is required when sizing circuit breakers and protection. Contact your local supplier for assistance.

PowerThrough remains active until 3-phase control only is reselected.

PowerThrough operation does not support XLR-8 adaptive acceleration control soft starting or soft stopping. In PowerThrough, the EMX3 will automatically select constant current soft starting and timed voltage ramp soft stopping. If PowerThrough is enabled, parameters 2C and 2D must be set appropriately.



#### NOTE

PowerThrough only operates with in-line connected motors.

## I6 Protection Action

These parameters define how the soft starter will respond to different protection events. The soft starter can trip, issue a warning, or ignore different protection events as required. All protection events are written to the event log.

The default action for all protections is to trip the soft starter. Protections I6-N Ground Fault and I6-P ~ I6-V are only available if the RTD and ground fault protection card have been installed.



#### CAUTION

Defeating the protection can compromise the soft starter, motor and installation.

---

**I6A~I6U – Protection Actions**

---

<b>Options:</b>	<i>Trip Starter (Default)</i> <i>Warning and Log</i> <i>Log Only</i>
<b>Description:</b>	Selects the soft starter's response to each protection. <i>I6A Motor Overload</i> <i>I6B Excess Start Time</i> <i>I6C Undercurrent</i> <i>I6D Inst Overcurrent</i> <i>I6E Current Imbalance</i> <i>I6F Frequency</i> <i>I6G Input A Trip</i> <i>I6H Input B Trip</i> <i>I6I Motor Thermistor</i> <i>I6J Starter/Comms</i> <i>I6K Network Comms</i> <i>I6L Heatsink Overtemp</i> <i>I6M Battery/Clock</i> <i>I6N Ground Fault</i> <i>I6O~I6U RTD A~G Overtemp</i>

**20 Restricted**

These parameters are restricted for AuCom internal use and are not available to the user.

## Section 8 Troubleshooting

### 8.1 Trip Messages

The behaviour of the protection mechanisms listed in the following table can be adjusted using parameter group 3 *Protection Settings* and parameter group 16 *Protection Action*.

Display	Possible cause/Suggested solution
<b>Battery/Clock</b>	A verification error has occurred on the real time clock, or the backup battery voltage is low. The clock can be reprogrammed and the soft starter power cycled to reset. If the battery is low and the power is off, saved parameters will be lost. Related parameters: 16M
<b>Time - Overcurrent</b>	The EMX3 has drawn high current while bypassed. (The 10A protection curve has reached 120%.) Related parameters: none
<b>Current Imbalance</b>	Current imbalance can be caused by problems with the motor, the environment or the installation, such as: <ul style="list-style-type: none"> <li>• an imbalance in the incoming mains voltage</li> <li>• a problem with the motor windings</li> <li>• a light load on the motor</li> <li>• loss of one or more phases on the input or output</li> </ul> Current imbalance can also be caused by problems within the soft starter, or by incorrect cabling between the external bypass contactor and the soft starter. Check all power connections and cabling. Related parameters: 4H, 4I, 16E
<b>EEPROM Fail</b>	An error occurred loading data from the EEPROM to RAM when the keypad powered up. Remove and restore control voltage. If the problem persists, contact your local supplier. Related parameters: none
<b>FLC Too High</b>	The EMX3 can support higher motor FLC values when connected to the motor in inside delta configuration than in-line connection. If the soft starter is connected in-line but the selected motor FLC is above the in-line maximum, the soft starter will trip. Related parameters: 1A, 9B
<b>Frequency</b>	The mains frequency has gone beyond the specified range. Check for other equipment in the area that could be affecting the mains supply (particularly variable speed drives). If the EMX3 is connected to a generator set supply, the generator may be too small or could have a speed regulation problem. Related parameters: 4K, 4L, 16F
<b>Ground Fault</b>	Test the insulation of the output cables and the motor. Identify and resolve the cause of any ground fault. Related parameters: 4O, 4P, 16N
<b>Input A Trip</b>	Identify and resolve the condition which caused Input A to activate. Related parameters: 6A, 6C, 6D, 6E, 16G
<b>Input B Trip</b>	Identify and resolve the condition which caused Input B to activate. Related parameters: 6F, 6H, 6I, 6J, 16H
<b>Inst Overcurrent</b>	The motor has experienced a sharp rise in motor current, probably caused by a locked rotor condition (shearpin) while running. This may indicate a jammed load. Related parameters: 4E, 4F, 16D
<b>Internal Fault</b>	The EMX3 has tripped on an internal fault. Contact your local supplier with the fault code.
<b>Mtr Overload</b>	The motor has reached its maximum thermal capacity. Overload can be caused by excessive throughput or damaged motor bearings. Resolve the cause of the overload and allow the motor to cool. Related parameters: 1A, 1C, 1B, 1D, 9A, 9B, 9C, 9D, 9E, 16A
<b>L1 Shorted SCR</b> <b>L2 Shorted SCR</b> <b>L3 Shorted SCR</b>	One or more SCRs has failed the pre-start tests. Contact your local supplier. If it is more important to keep the application running than to safeguard the soft starter or motor, consider enabling PowerThrough operation (parameter 15D). Related parameters: 15D

<b>Motor Connection</b>	The motor is not connected correctly to the soft starter. Check each output phase of the soft starter for power circuit continuity. Related parameters: none
<b>Motor Thermistor</b>	The resistance at the thermistor input has exceeded 3.6 k $\Omega$ or fallen below 100 $\Omega$ for more than one second. The motor winding has overheated. Identify the cause of the overheating and allow the motor to cool before restarting. If you are not using a thermistor, you must attach a 1.2 k $\Omega$ resistor across terminals B4-B5. Related parameters: I6-I
<b>Network Comms</b>	The network master has sent a trip command to the starter, or there may be a network communication problem. Check the network for causes of inactivity. Related parameters: I6K
<b>Phase Sequence</b>	The phase sequence on the soft starter's input terminals (L1, L2, L3) is not valid. Check the phase sequence on L1, L2, L3 and ensure the setting in parameter 4G is suitable for the installation. Related parameters: 4G
<b>Power Loss</b>	The EMX3 is not receiving mains supply on one or more phases. Check that the mains supply is connected to L1, L2, L3 and all fuses are healthy. Check that the main contactor closes when a start command is given, and remains closed until the end of a soft stop. Related parameters: 20B
<b>Starter/Comms</b>	There is a problem with the connection between the soft starter and the serial communications module, or the communications module has failed. Remove and reinstall the module. Contact your local supplier if the problem persists. Related parameters: I6J
<b>Undercurrent</b>	The motor has experienced a sharp drop in current, caused by loss of load. Causes can include broken components (shafts, belts or couplings), or a pump running dry. Related parameters: 4C, 4D, I6C

## 8.2 Protection Responses

When a protection condition is detected, the EMX3 will write this to the event log and may also trip or issue a warning. The soft starter's response to some protections may depend on the Protection Action settings (parameter group I6).

If the EMX3 trips you will need to reset the soft starter before restarting. If the EMX3 has issued a warning, the soft starter will reset itself once the cause of the warning has been resolved.

Some protections cause a fatal trip. This response is pre-defined and cannot be overridden. These protection mechanisms are designed to protect the soft starter, or can be caused by a fault within the soft starter.

**8.3 General Faults**

This table describes situations where the soft starter does not operate as expected but does not trip or give a warning.

Symptom	Probable Cause
Soft starter does not respond to commands.	<ul style="list-style-type: none"> <li>If the soft starter does not respond to the <b>START</b> or <b>RESET</b> button on the keypad:                             <ul style="list-style-type: none"> <li>The soft starter may be in Remote control mode. When the soft starter is in Remote control mode, the Remote LED on the keypad is active. Press the <b>LCL/RMT</b> button once to change to Local control (refer to parameter 6Q <i>Local/Remote Control</i> for details).</li> </ul> </li> <li>If the soft starter does not respond to commands from the control inputs:                             <ul style="list-style-type: none"> <li>The soft starter may be in Local control mode. When the soft starter is in Local control mode, the Remote LED on the keypad is not active. Press the <b>LCL/RMT</b> button once to change to Remote control (refer to parameter 6Q <i>Local/Remote Control</i> for details).</li> <li>The control wiring may be incorrect. Check that the remote start, stop and reset inputs are configured correctly (refer to <i>Control Wiring</i> for details).</li> <li>The signals to the remote inputs may be incorrect. Test the signalling by activating each input signal in turn. The appropriate remote control input LED should activate on the keypad.</li> <li>The soft starter will only execute a start command from the remote inputs if the remote reset input is closed. Check that the remote reset input is also active (the Reset LED on the starter will be on).</li> </ul> </li> <li>If the soft starter does not respond to a start command from either the local or remote controls:                             <ul style="list-style-type: none"> <li>The soft starter may be waiting for the restart delay to elapse. The length of the restart delay is controlled by parameter 4M <i>Restart Delay</i>.</li> <li>The motor may be too hot to permit a start. If parameter 4N <i>Restart Temperature Check</i> is set to Check, the soft starter will only permit a start when it calculates that the motor has sufficient thermal capacity to complete the start successfully. Wait for the motor to cool before attempting another start.</li> <li>The emergency stop function may be active. If parameter 6A or 6F is set to Emergency Stop and there is an open circuit on the corresponding input, the EMX3 will not start. If the emergency stop situation has been resolved, close the circuit on the input.</li> </ul> </li> </ul>
The soft starter does not control the motor correctly during starting.	<ul style="list-style-type: none"> <li>Start performance may be unstable when using a low Motor Full Load Current setting (parameter 1A). This can affect use on a small test motor with full load current between 5 A and 50 A.</li> <li>Power factor correction (PFC) capacitors must be installed on the supply side of the soft starter. To control a dedicated PFC capacitor contactor, connect the contactor to run relay terminals.</li> </ul>
Motor does not reach full speed.	<ul style="list-style-type: none"> <li>If the start current is too low, the motor will not produce enough torque to accelerate to full speed. The soft starter may trip on excess start time.                             <div style="margin-left: 20px;">  <p><b>NOTE</b> Make sure the motor starting parameters are appropriate for the application and that you are using the intended motor starting profile. If parameter 6A or 6F is set to Parameter Set Selection, check that the corresponding input is in the expected state.</p> </div> </li> <li>The load may be jammed. Check the load for severe overloading or a locked rotor situation.</li> </ul>

Erratic motor operation.	<ul style="list-style-type: none"> <li>The SCRs in the EMX3 require at least 5 A of current to latch. If you are testing the soft starter on a motor with full load current less than 5 A, the SCRs may not latch correctly.</li> </ul>
Soft stop ends too quickly.	<ul style="list-style-type: none"> <li>The soft stop settings may not be appropriate for the motor and load. Review the settings of parameters 2H, 2I, 10H and 10I.</li> <li>If the motor is very lightly loaded, soft stop will have limited effect.</li> </ul>
Corrupted text shown on keypad display.	<ul style="list-style-type: none"> <li>The keypad may not be screwed down, resulting in an intermittent connection. Screw down the keypad or hold squarely in place.</li> </ul>
XLR-8 adaptive acceleration control, DC brake and Jog functions not working	<ul style="list-style-type: none"> <li>Check if you have a 6-wire installation. Only operate in 3-wire.</li> </ul>
A reset does not occur after an Auto-Reset, when using a remote 2-wire control.	<ul style="list-style-type: none"> <li>The remote 2-wire start signal must be removed and reapplied for a re-start.</li> </ul>
Remote start/stop command is overriding Auto Start/Stop settings when using remote 2-wire control.	<ul style="list-style-type: none"> <li>Auto Start/Stop function should only be used in LOCAL mode or in tandem with REMOTE mode, 3 and 4-wire control.</li> </ul>
After selecting XLR-8 the motor used an ordinary start and/or the second start was different to the first.	<ul style="list-style-type: none"> <li>The first XLR-8 is current limit so that the starter can learn from the motor characteristics. Subsequent starts use XLR-8.</li> </ul>
Non-resettable THERMISTOR FAIL trip, when there is a link between Thermistor input B4/B5.	<ul style="list-style-type: none"> <li>The Thermistor input is enabled once a link is fitted and short circuit protection has activated. Place a 1k2 ohm resistor across the Thermistor input.</li> </ul>
Display is distorted	<ul style="list-style-type: none"> <li>Check that the keypad has not be screwed down to tight. Loosen screws off slightly.</li> </ul>
Parameter settings cannot be stored.	<ul style="list-style-type: none"> <li>Make sure you are saving the new value by pressing the <b>STORE</b> button after adjusting a parameter setting. If you press <b>◀</b>, the change will not be saved.</li> <li>Check that the adjustment lock (parameter 15B) is turned off. If the adjustment lock is on, settings can be viewed but not changed. You need to know the security access code to change the adjustment lock setting.</li> <li>The EEPROM may be faulty on the keypad or the power interface PCB. A faulty EEPROM will also trip the soft starter, and the keypad will display the message EEPROM Fail. Contact your local supplier for advice.</li> </ul>

**Section 9 Appendix**

**9.1 Specifications**

**Model Codes**

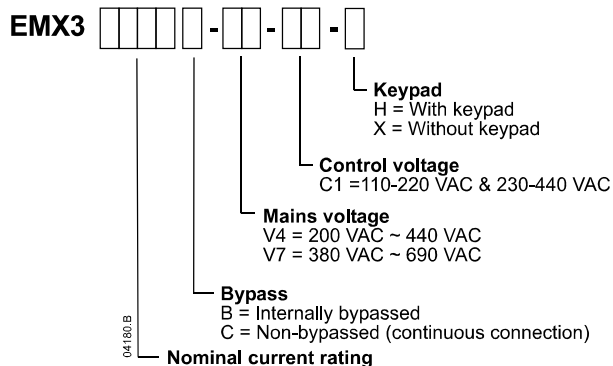

• **Current Ratings - Bypass Operation**

	3.0 x FLC		3.5 x FLC		4.0 x FLC		4.5 x FLC	
	AC53b 3.0-10:350 40 °C <1000 metres		AC53b 3.5-15:345 40 °C <1000 metres		AC53b 4.0-20:340 40 °C <1000 metres		AC53b 4.5-30:330 40 °C <1000 metres	
	Inline	Inside delta	Inline	Inside delta	Inline	Inside delta	Inline	Inside delta
EMX3-0023B	23 A	35 A	20 A	30 A	17 A	26 A	15 A	22 A
EMX3-0043B	43 A	65 A	40 A	59 A	34 A	51 A	29 A	44 A
EMX3-0050B	50 A	75 A	44 A	66 A	37 A	55 A	30 A	45 A
EMX3-0053B	53 A	80 A	53 A	80 A	46 A	69 A	37 A	55 A
	AC53b 3.0-10:590 40 °C <1000 metres		AC53b 3.5-15:585 40 °C <1000 metres		AC53b 4.0-20:580 40 °C <1000 metres		AC53b 4.5-30:570 40 °C <1000 metres	
EMX3-0076B	76 A	114 A	64 A	96 A	55 A	83 A	47 A	70 A
EMX3-0097B	97 A	146 A	82 A	123 A	69 A	104 A	58 A	87 A
EMX3-0100B	100 A	150 A	88 A	132 A	74 A	112 A	61 A	92 A
EMX3-0105B	105 A	158 A	105 A	158 A	95 A	143 A	78 A	117 A
EMX3-0145B	145 A	218 A	123 A	184 A	106 A	159 A	90 A	136 A
EMX3-0170B	170 A	255 A	145 A	217 A	121 A	181 A	97 A	146 A
EMX3-0200B	200 A	300 A	189 A	283 A	160 A	241 A	134 A	200 A
EMX3-0220B	220 A	330 A	210 A	315 A	178 A	268 A	148 A	223 A

**90 A: AC-53b 3.5-15 : 345**



Contact your local supplier for ratings under operating conditions not covered by the above ratings charts.

• Current Ratings - Continuous Operation (Not bypassed)

	AC53a 3-10:50-6 40 °C <1000 metres		AC53a 3.5-15:50-6 40 °C <1000 metres		AC53a 4-20:50-6 40 °C <1000 metres		AC53a 4.5-30:50-6 40 °C <1000 metres	
	Inline	Inside delta	Inline	Inside delta	Inline	Inside delta	Inline	Inside delta
EMX3-0255C	255 A	382 A	222 A	334 A	195 A	293 A	171 A	257 A
EMX3-0360C	360 A	540 A	351 A	527 A	303 A	455 A	259 A	388 A
EMX3-0380C	380 A	570 A	380 A	570 A	348 A	522 A	292 A	437 A
EMX3-0430C	430 A	645 A	413 A	620 A	355 A	533 A	301 A	451 A
EMX3-0620C	620 A	930 A	614 A	920 A	515 A	773 A	419 A	628 A
EMX3-0650C	650 A	975 A	629 A	943 A	532 A	798 A	437 A	656 A
EMX3-0790C	790 A	1185 A	790 A	1185 A	694 A	1041 A	567 A	850 A
EMX3-0930C	930 A	1395 A	930 A	1395 A	800 A	1200 A	644 A	966 A
EMX3-1200C	1200 A	1800 A	1200 A	1800 A	1135 A	1702 A	983 A	1474 A
EMX3-1410C	1410 A	2115 A	1355 A	2033 A	1187 A	1780 A	1023 A	1535 A
EMX3-1600C	1600 A	2400 A	1600 A	2400 A	1433 A	2149 A	1227 A	1840 A

**78 A: AC-53a 3.5-15 : 50-10**

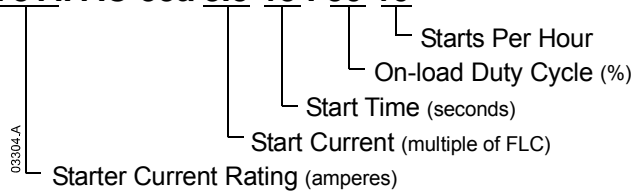

Contact your local supplier for ratings under operating conditions not covered by the above ratings charts.

Dimensions and Weights

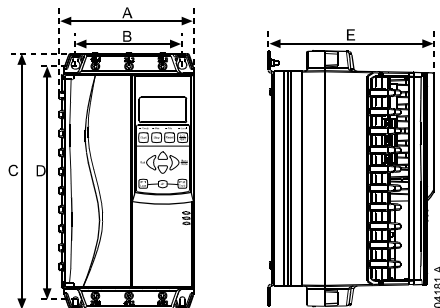

Model	A mm (inches)	B mm (inches)	C mm (inches)	D mm (inches)	E mm (inches)	Weight kg (lbs)
EMX3-0023B					192.2 (7.57)	3.2 (7.05)
EMX3-0043B						
EMX3-0050B						
EMX3-0053B	156.4 (6.16)	124.0 (4.88)	294.6 (11.60)	278.0 (10.94)		3.5 (7.22)
EMX3-0076B						
EMX3-0097B					222.7 (8.77)	4.8 (10.58)
EMX3-0100B						
EMX3-0105B						
EMX3-0145B						
EMX3-0170B	282 (11.10)	250 (9.84)	438 (17.24)	380 (14.96)	250 (9.84)	16 (35.27)
EMX3-0200B						
EMX3-0220B						
EMX3-0255C	390 (15.35)	320 (12.60)	417 (16.42)	400 (15.75)	281 (11.06)	25 (55.12)
EMX3-0360C						
EMX3-0380C						
EMX3-0430C						
EMX3-0620C	430 (16.93)	320 (12.60)	545 (21.46)	522 (20.55)	299 (11.77)	50.5 (111.33)
EMX3-0650C						
EMX3-0790C						
EMX3-0930C						
EMX3-1200C						
EMX3-1410C	574 (22.60)	500 (19.69)	750 (29.53)	727 (28.62)	361 (14.21)	136 (299.83)
EMX3-1600C						



NOTE

For EMX3-0145B ~ EMX3-1600C, dimensions A and C are the unit footprint. Bus bars are not included as this dimension will vary with bus bar configuration.

## General Technical Data

Supply	
Mains voltage (L1, L2, L3)	
EMX3-xxxx-V4 .....	200 VAC ~ 440 VAC ( $\pm 10\%$ )
EMX3-xxxx-V7 .....	380 VAC ~ 690 VAC ( $\pm 10\%$ ) (in-line connection)
EMX3-xxxx-V7 .....	380 VAC ~ 600 VAC ( $\pm 10\%$ ) (inside delta connection)
Control voltage (A1, A2, A3).....	110 ~ 220 VAC or 230 ~ 440 VAC (+ 10% / -15%), 100mA
Mains frequency .....	45 Hz to 66 Hz
Rated insulation voltage to earth .....	600 VAC
Rated impulse withstand voltage .....	4 kV
Form designation .....	Bypassed or continuous, semiconductor motor starter form 1
Short circuit capability	
Coordination with semiconductor fuses.....	Type 2
Coordination with HRC fuses.....	Type 1
EMX3-0023B to EMX3-0105B .....	prospective current 10 kA
EMX3-0145B to EMX3-0255C .....	prospective current 18 kA
EMX3-0360C to EMX3-0930C .....	prospective current 85 kA
EMX3-1200C to EMX3-1600C .....	prospective current 100 kA
Inputs	
Inputs .....	Active 24 VDC, 8 mA approx
Start (C23, C24) .....	Normally open
Stop (C31, C32) .....	Normally closed
Reset (C41, C42) .....	Normally closed
Programmable Inputs	
Input A (C53, C54) .....	Normally open
Input B (C63, C64) .....	Normally open
Motor Thermistor (B4, B5) .....	Trip >3.6 k $\Omega$ , reset <1.6k $\Omega$
PT100 RTD (B6, B7, B8) .....	Accuracy 0 ~ 100 °C $\pm 0.5$ °C, 100 °C ~ 150 °C $\pm 2$ °C, -20 ~ 0 °C $\pm 2$ °C
Outputs	
Relay Outputs .....	10A @ 250 VAC resistive, 5A @ 250 VAC AC15 pf 0.3
Run Relay (23, 24) .....	Normally open
Programmable Outputs	
Relay A (13, 14) .....	Normally open
Relay B (31, 32, 34) .....	Changeover
Relay C (41, 42, 44) .....	Changeover
Analog Output (B10, B11) .....	0-20 mA or 4-20 mA (selectable)
Maximum load .....	600 $\Omega$ (12 VDC @ 20 mA)
Accuracy .....	$\pm 5\%$
24 VDC Output (P24, COM) Maximum load	
EMX3-0023B ~ EMX3-0220B.....	60 mA
EMX3-0255C ~ EMX3-1600C .....	200 mA
Accuracy .....	$\pm 10\%$
Environmental	
Protection	
EMX3-0023B ~ EMX3-0105B .....	IP20 & NEMA 1
EMX3-0145B ~ EMX3-1600C .....	IP00
Keypad (when installed with remote mounting kit) .....	IP65 & NEMA 12
Operating temperature .....	-10 °C to 60 °C, above 40 °C with derating
Storage temperature .....	-25 °C to + 60 °C
Operating Altitude.....	0 - 1000 m, above 1000 m with derating
Humidity .....	5% to 95% Relative Humidity
Pollution degree .....	Pollution Degree 3
Electromagnetic capability (compliant with EU Directive 89/336/EEC)	
EMC Emissions.....	IEC 60947-4-2 Class A and Lloyds Marine No 1 Specification
EMC Immunity.....	IEC 60947-4-2
This product has been designed for Class A equipment. Use of the product in domestic environments may cause radio interference, in which case the user may be required to employ additional mitigation methods.	

Heat Dissipation	
During start .....	4.5 watts per ampere
During run	
EMX3-0023B ~ EMX3-0053B .....	≤ 39 watts approx
EMX3-0076B ~ EMX3-0105B .....	≤ 51 watts approx
EMX3-0145B ~ EMX3-0220B .....	≤ 120 watts approx
During run	
EMX3-0255C ~ EMX3-0930C .....	4.5 watts per ampere approx
EMX3-1200C ~ EMX3-1600C .....	4.5 watts per ampere approx
Certification	
C✓ .....	IEC 60947-4-2
UL/ C-UL .....	UL 508, UL 347
EMX3-0023B ~ EMX3-0105B.....	Indoor, Enclosed, Type I
EMX3-0145B ~ EMX3-1600C.....	Indoor, Open Type.
CE .....	IEC 60947-4-2
CCC .....	GB 14048-6
Marine (EMX3-0023B ~ EMX3-0220B only) .....	Lloyds Marine No 1 Specification
RoHS .....	Compliant with EU Directive 2002/95/EC

## 9.2 Accessories

### Communication Modules

EMX3 soft starters support network communication using the Profibus, DeviceNet and Modbus RTU protocols, via an easy-to-install communications module.

### Hardware Expansion Cards

The EMX3 offers hardware expansion cards for users requiring additional inputs and outputs or advanced functionality. Each EMX3 can support a maximum of one expansion card.

- **Input/Output**

Part Number: 995-04803-00

The input/output expansion card provides the following additional inputs and outputs:

- 2 x inputs
- 3 x output relays
- 1 x analog input
- 1 x analog output

- **RTD/Ground Fault**

Part Number: 995-04804-00

The RTD and ground fault protection card provides the following additional inputs:

- 6 x PT100 RTD inputs
- 1 x ground fault input

To use ground fault protection a 1000:1, 5 VA current transformer is also required.

- **Keypad Mounting Kit**

Part Number: 995-04939-00

The keypad mounting kit allows remote mounting of the keypad up to 1.8m away from the soft starter.

### PC Software

WinMaster PC software provides monitoring, programming and control of up to 99 EMX3 soft starters.

A Modbus communication module is required for each EMX3 to use WinMaster.

### 9.3 Parameter Values

If you require assistance from your supplier or a service technician, please note all parameter settings in the table below.

	Motor Data-1	User Set 1	User Set 2
1A	Motor Full Load Current		
1B	Locked Rotor Time		
1C	Locked Rotor Current		
1D	Motor Service Factor		
<b>2</b>	<b>Start/Stop Modes-1</b>		
2A	Start Mode		
2B	Start Ramp Time		
2C	Initial Current		
2D	Current Limit		
2E	Adaptive Start Profile		
2F	Kickstart Time		
2G	Kickstart Level		
2H	Stop Mode		
2I	Stop Time		
2J	Adaptive Stop Profile		
2K	Adaptive Control Gain		
2L	Brake Torque		
2M	Brake Time		
<b>3</b>	<b>Auto-Start/Stop</b>		
3A	Auto-Start Type		
3B	Auto-Start Time		
3C	Auto-Stop Type		
3D	Auto-Stop Time		
<b>4</b>	<b>Protection Settings</b>		
4A	Excess Start Time		
4B	Excess Start Time-2		
4C	Undercurrent Level		
4D	Undercurrent Trip Delay		
4E	Instantaneous Overcurrent Level		
4F	Instantaneous Overcurrent Trip Delay		
4G	Phase Sequence		
4H	Current Imbalance Level		
4I	Current Imbalance Trip Delay		
4J	Frequency Check		
4K	Frequency Variation		
4L	Frequency Trip Delay		
4M	Restart Delay		
4N	Motor Temperature Check		
4O	Ground Fault Level		
4P	Ground Fault Trip Delay		
<b>5</b>	<b>Auto-Reset Trips</b>		
5A	Auto-Reset Action		
5B	Maximum Reset Attempts		
5C	Auto-Reset Delay Group A and B Trips		
5D	Auto-Reset Delay Group C Trips		

## APPENDIX

6		Inputs	
6A	Input A Function		
6B	Input A Name		
6C	Input A Trip		
6D	Input A Trip Delay		
6E	Input A Initial Delay		
6F	Input B Function		
6G	Input B Name		
6H	Input B Trip		
6I	Input B Trip Delay		
6J	Input B Initial Delay		
6E	Input C Function		
6L	Input D Function		
6M	Remote Reset Logic		
6N	Analog Input Trip		
6O	Analog Input Scale		
6P	Analog Trip Point		
6Q	Local/Remote Button		
6R	Comms Control in Remote Mode		
7		Outputs	
7A	Relay A Function		
7B	Relay A On Delay		
7C	Relay A Off Delay		
7D	Relay B Function		
7E	Relay B On Delay		
7F	Relay B Off Delay		
7G	Relay C Function		
7H	Relay C On Delay		
7I	Relay C Off Delay		
7J	Relay D Function		
7K	Relay E Function		
7L	Relay F Function		
7M	Low Current Flag		
7N	High Current Flag		
7O	Motor Temperature Flag		
7P	Analog Output A Function		
7Q	Analog Output A Scale		
7R	Analog A Maximum Adjustment		
7S	Analog A Minimum Adjustment		
7T	Analog Output B Function		
7U	Analog Output B Scale		
7V	Analog B Maximum Adjustment		
7W	Analog B Minimum Adjustment		

<b>8</b>	<b>Display</b>		
8A	Language		
8B	F1 Button Action		
8C	F2 Button Action		
8D	Display Current or Kilowatts		
8E	User-Programmable Screen – Top Left		
8F	User-Programmable Screen – Top Right		
8G	User-Programmable Screen – Bottom Left		
8H	User-Programmable Screen – Bottom Right		
8I	Graph Data		
8J	Graph Timebase		
8K	Graph Maximum Adjustment		
8L	Graph Minimum Adjustment		
8M	Current Calibration		
8N	Mains Reference Voltage		
<b>9</b>	<b>Motor Data-2</b>		
9A	Dual Thermal Model		
9B	Motor Full Load Current-2		
9C	Locked Rotor Time-2		
9D	Locked Rotor Current-2		
9E	Motor Service Factor-2		
<b>10</b>	<b>Start/Stop Modes-2</b>		
10A	Start Mode-2		
10B	Start Ramp Time-2		
10C	Initial Current-2		
10D	Current Limit-2		
10E	Adaptive Start Profile-2		
10F	Kickstart Time-2		
10G	Kickstart Level-2		
10H	Stop Mode-2		
10I	Stop Time-2		
10J	Adaptive Stop Profile-2		
10K	Adaptive Control Gain-2		
10L	Brake Torque-2		
10M	Brake Time-2		
<b>11</b>	<b>RTD Temperatures</b>		
11A	RTD A Trip Temperature		
11B	RTD B Trip Temperature		
11C	RTD C Trip Temperature		
11D	RTD D Trip Temperature		
11E	RTD E Trip Temperature		
11F	RTD F Trip Temperature		
11G	RTD G Trip Temperature		
<b>12</b>	<b>Slip-Ring Motors</b>		
12A	Motor Data-1 Ramp		
12B	Motor Data-2 Ramp		
12C	Changeover Contactor Time		
12D	Slip-Ring Conduction Retard		

## APPENDIX

15	<b>Advanced</b>		
I5A	Access Code		
I5B	Adjustment Lock		
I5C	Emergency Run		
I5D	Shorted SCR Action		
21	<b>Protection Actions</b>		
I6A	Motor Overload		
I6B	Excess Start Time		
I6C	Undercurrent		
I6D	Instantaneous Overcurrent		
I6E	Current Imbalance		
I6F	Frequency		
I6G	Input A Trip		
I6H	Input B Trip		
I6I	Motor Thermistor		
I6J	Starter Communication Timeout		
I6K	Network Communication Trip		
I6L	Heatsink Overtemperature		
I6M	Battery/Clock Failure		
I6N	Ground Fault		
I6O	RTD A Overtemperature		
I6P	RTD B Overtemperature		
I6Q	RTD C Overtemperature		
I6R	RTD D Overtemperature		
I6S	RTD E Overtemperature		
I6T	RTD F Overtemperature		
I6U	RTD G Overtemperature		
20	Restricted	N/A	N/A

**Section 10 Authorised Representatives**

<p>AuCom Electronics Limited</p>	<p>123 Wrights Rd PO Box 80208 Christchurch 8440 New Zealand Phone: +64 3 338 8280 Fax: +64 3 338 8104 Email: contact@aucom.com</p>
<p>Australia NHP Electrical Engineering Pty Limited</p>	<p>43-67 River Street Richmond, Victoria 3121 Australia Phone: +61 3 9429 2999 Fax: +61 3 9428 6909 Email: australia@aucom.com</p>
<p>Canada Saftronics Incorporated</p>	<p>5580 Enterprise Parkway Fort Myers, Florida FL 33905 United States of America Phone: +1 239 693 7200 Fax: +1 239 693 2431 Email: canada@aucom.com</p>
<p>Chile Rhona S.A.</p>	<p>Agua Santa 4211 Casilla 30-D Vina del Mar Chile Phone: +56 32 2 320600 Fax: +56 32 2 320618 Email: chile@aucom.com</p>
<p>China AuCom Shanghai Representative Office</p> <p>Sanch Organization</p>	<p>Room 3506, Bank of China Tower 200, Yincheng Road, Central Pudong Shanghai 200120, PRC Phone: +86 21 5877 5178 Fax: +86 21 5877 6378 Email: contact@aucom.com.cn</p> <p>Room 505, Fudan Technology Building No. 11, Guotai Road Shanghai 200433 China Phone: +86 21 5169 6555 Fax: +86 21 6140 0501</p> <p>No. 3, Zixin Road Jiangnan Hi-Tech Electronic Information Industrial Zone Licheng District, Quanzhou City Fujian Province China Phone: +86 595 2898 3300 Fax: +86 595 2898 3388 Email: china@aucom.com</p>
<p>Colombia C.I ESI de Colombia S.A.</p>	<p>Avenida Carrera 97 No. 24c-51 Bodega 14 Bogota Colombia Phone: +57 1 404 3333 Fax: +57 1 404 5048 Email: colombia@aucom.com</p>

## AUTHORISED REPRESENTATIVES

Egypt TEM Engineering	69 El Fosat Building, Flat 13 P O Box 39 El Dawaween Cairo 11521 Egypt Phone: +20 2 9186042 Fax: +20 2 7958568 Email: <a href="mailto:egypt@aucom.com">egypt@aucom.com</a>
Greece Valiadis & Co Limited	10, G.Labraki Str 14123 Likovrissi Athens Greece Phone: +30 10 281 7217 Fax: +32 10 281 4277 Email: <a href="mailto:greece@aucom.com">greece@aucom.com</a>
India Larsen & Toubro Limited	Automation Systems Centre EL-200, TTC Electronic Zone Shil-Mahape Road Navi Mumbai 400 710, India Phone: +91 22 5591 6373 Fax: +91 22 2761 1590 Email: <a href="mailto:india@aucom.com">india@aucom.com</a>
Indonesia PT. Winindo Karya Dinamika	Jl. Ciputat Raya 8 H Kompleks Pinang 8 Pondok Pinang Jakarta Selatan 12310 Indonesia Phone: +62 21 769 7383 Fax: +62 21 7590 5777 Email: <a href="mailto:indonesia@aucom.com">indonesia@aucom.com</a>
Iran Parto Sanat Company	No:1281, Valli Asr Ave., Next to 14th Gandhi St. Tehran, IRAN Postcode: 1517843315 Tel: +98 (0) 21 8866 2288 Fax: +98 (0) 21 8888 7809 Email: <a href="mailto:iran@aucom.com">iran@aucom.com</a>
Lebanon Al Rawan s.a.l	Sea St Mustapha Saleh Bldg P O Box 260 Saida, Ghazieh Lebanon Phone: +961 7 222401 Fax: +961 7 221799 Email: <a href="mailto:lebanon@aucom.com">lebanon@aucom.com</a>
Malaysia Hi-Tech Drives (M) Sdn Bhd	36, Jalan Taboh 33/22 Shah Alam Technology Park Section 33, 40400 Shah Alam Selangor DE Malaysia Phone: +60 3 5124 9498 Fax: +60 3 5124 9478 Email: <a href="mailto:malaysia@aucom.com">malaysia@aucom.com</a>
Mexico Saftronics Incorporated	5580 Enterprise Parkway Fort Myers, Florida FL 33905 United States of America Phone: +1 239 693 7200 Fax: +1 239 693 2431 Email: <a href="mailto:mexico@aucom.com">mexico@aucom.com</a>

Micronesia Asia Pacific Industries, Incorporated	PO Box 5308 CHRB Saipan MP 96950 Phone: +1 670 233 9219 Fax: +1 670 233 9216 Email: micronesia@aucom.com
Morocco AUXEL	80 Route Ouled Ziane 20500 Casablanca Morocco Phone: +212 22 440966 Fax: +212 22 440953 Email: morocco@aucom.com
Netherlands Electro Drive B.V. Zaandam Nederland	Postbus 90 NL-1500EB Zaandam Netherlands Phone: +31 75 616 6656 Fax: +31 75 617 9500 Email: netherlands@aucom.com
Pakistan Speedy Automation	9, Manzoor Square, 1st Floor, Noman Street, Karachi - 74400, Pakistan PO Box 7513, Saddar, Karachi - 7400 Phone: +92 21 2722953 Fax : 92-21-2736884 Email: pakistan@aucom.com
Peru Manufacturas Electricas S.A.	Av. Mrcal. Oscar Benavides 1215 Lima I, Lima Peru Phone: +51 1 337 0058 Fax: +51 1 425 4884 Email: peru@aucom.com
Philippines Asia Pacific Industrial Equipment Sales and Service	Bgy. Putlod, Jaen Nueva Ecija Phone: +63 44 486 5638 Email: philippines@aucom.com
Poland Zeltech S.A.	ul. Elektronowa 6 94-103 Łódź Poland Phone: +48 42 686 34 56 Fax: +48 42 6861970 Email: poland@aucom.com
Russian Federation Stoik Limited	7, Prostornaya Str. Moscow Russian Federation Phone: +7 495 6612441 Fax: +7 495 6612441 Email: russia@aucom.com
Singapore Invertex Drives Far East Pte Limited	10 Tractor Road, Jurong Industrial Estate Mailing Address: Jurong West Post Office, PO Box 1012, Singapore 919431 Phone: +65 6100 4600 Fax : + 65 68983033 Email: singapore@aucom.com
South Africa CHI Control Components	Cnr. Osborn & Esandar Roads Wadeville 1407 Johannesburg South Africa Phone: +27 11 827 9124 Fax: +27 11 827 3924 Email: south.africa@aucom.com

## AUTHORISED REPRESENTATIVES

South Korea C & A Electric Co Limited	7206, 7th Dongil Technotown 823 Kwanyang-Dong Dongan-gu Anyang City Kyungki-Do Korea Phone: +82 314230135 Fax: +82 314230136 Email: south.korea@aucom.com
Slovakia PWMotor s.r.o	Jurska I 831 02 Bratislava Slovakia Phone: +421 2 4463 52461 Fax: +421 2 4445 0188 Email: slovakia@aucom.com
Spain SIDE	08480 L'Ametlla del Valles, Barcelona Spain Phone: +34 93 846 4801 Fax: +34 93 8491394 Email: spain@aucom.com
Taiwan Shuyo Enterprise Co Limited	No.83 Shangsing Rd Lujhu Township Taoyuan County 33857 Taiwan Phone: +886 3 323 5668 Fax: +886 3 323 5638 Email: taiwan@aucom.com
Thailand W.T. Engineering Co. Limited	4/49 Moo 10 Srinakarin Rd Bangna, Bangna Bangkok 10260 Thailand Phone: +66 2 710 5240 Fax: +66 2 710 5244 Email: thailand@aucom.com
Turkey Koneksis Muhendislik, Muteahhitlik, Danismanlik, Dis Ticaret	Yedpa Ticaret Merkezi, G Caddesi No: 8, Yukari Dudullu, 34775 Umraniye Istanbul Phone: +90 216 4710625 Fax: +90 216 4710719 Email: turkey@aucom.com
United Kingdom Scattergood and Johnson Limited	Lowfields Road Leeds, LS12 6ET England Phone: +44 113 2430203 Fax: +44 113 2420959 Email: united.kingdom@aucom.com
United States Saftronics Incorporated	5580 Enterprise Parkway Fort Myers, Florida FL 33905 United States of America Phone: +1 239 693 7200 Fax: +1 239 693 2431 Email: united.states@aucom.com
Viet Nam Indochina Automation JSC	35 To Vinh Dien Street Khuong Trung Ward Thanh Xuan Distr Hanoi Viet Nam Phone: +84 4 5680 582 / 5680 583 Fax: +84 4 5680 581 Email: vietnam@aucom.com